

# WEKA Visual Level Indicators VLI

✓  
Certified according  
ISO 9001

✓  
Certified according  
PED

✓  
Certified according  
ATEX/IECEx

# Principles of design

## ● Single-pole Magnet System

The WEKA VLI operating principle is based on the use of a permanent bar magnet system which ensures the safe and reliable activation of visual indication elements (flags), switches and transmitters, even when used on thick-wall high-pressure indicator pipe.

## ● Magnetic Guide Tape

The patented magnetic guide tape is integrated within the indication rail to ensure the float bar magnet is always aligned like a compass needle to the polarized flags and switches. This ensures continuous reliability of the indicating, switching and transmitter control functions.

## ● Magnetic Coupling

Every flag of the WEKA indication rail is equipped with its own permanent magnet. Thus the indication flags magnetically interlock with each other and so are kept in a stable position. The patented guide tape further enhances performance through the magnetic damping effect that produces safe and reliable indication of liquid level, even under difficult applications with rapidly changing liquid levels or vibrations.

## ● Temperature Stability

The magnetic materials used in the WEKA System have been selected for optimal performance even at extreme temperatures. Years of experience have proven our preconditioning of components ensuring negligible degradation of magnetic flux.

## ● Compact Design

The low weight of the WEKA bar magnet permits the use of lightweight hermetically sealed floats. Compact in size, the WEKA floats ensure the highest possible diameter difference between float OD and tube ID – an important advantage when dirty or highly viscous liquids need to be measured. The short float design also often enables a larger indication range compared to competitive products.

## ● Multi-functional: Three functions in one system!

- Level indicator
- Level switch
- Level transmitter

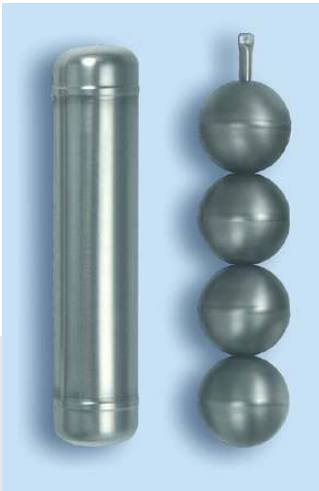

Diverse float types are available for the different applications

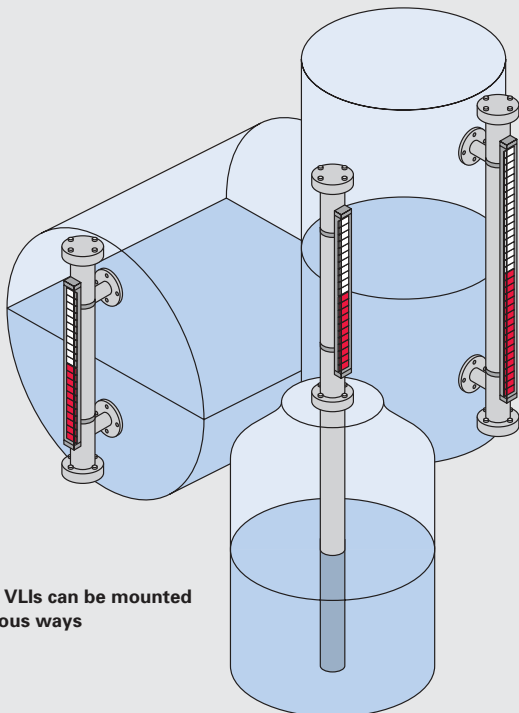

WEKA VLIs can be mounted in various ways

Pipe

Float

Bar magnet

Magnetic guide tape

Indication flags with integrated permanent magnets

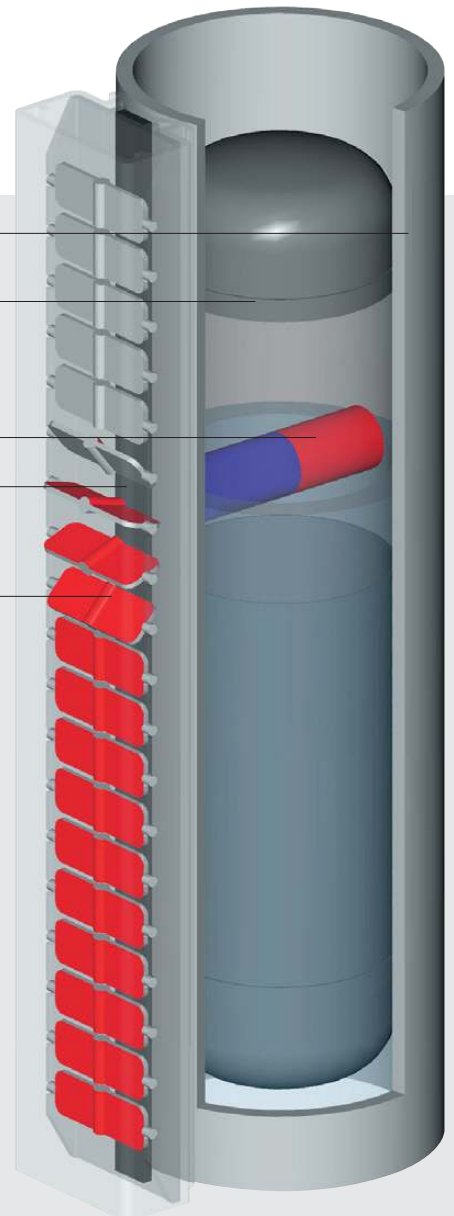

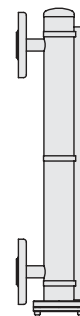
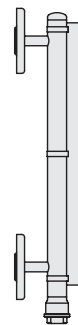

| Series                             | Economy-Line            | Economy-Line            |
|------------------------------------|-------------------------|-------------------------|
| Type                               | 34000E                  | 23614E                  |
| Execution                          | A, K                    | A, K                    |
| Max. operating pressure @ 20 °C    | up to 6 bar             | up to 6 bar             |
| Operating temperature              | -40 up to +100 °C       | -40 up to +100 °C       |
| Pipe size                          | OD 33.7 mm              | OD 53 mm                |
| Minimum density                    | > 0.6 g/cm <sup>3</sup> | > 0.8 g/cm <sup>3</sup> |
| Recommended viscosity of the fluid | max. 150 cSt            | max. 600 cSt            |

All data are valid for the basic versions

## ● Modular Design

The WEKA VLI (Visual Level Indicator) program is built up in a modular system. It can therefore be readily configured to precisely match the requirements of a very wide variety of applications and operating conditions. Within each series the basic execu-

tions -A, -B, -K and -O are available: Upper and lower process connections can be top to bottom or side to side. But also mixed versions with a lateral and side process connection can be ordered.

### Execution-A

Upper and lower process ports: top to bottom  
Upper float chamber end: threaded cap  
Lower float chamber end: threaded flange



### Execution -B

Upper and lower process ports: top to bottom  
Upper and lower float chamber ends: threaded flange



### Execution -K

Upper and lower process ports: side to side  
Upper float chamber end: cap  
Lower float chamber end: service flange

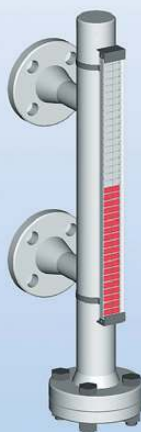

### Execution -O

Upper and lower process ports: side to side  
Upper and lower float chamber ends: service flange



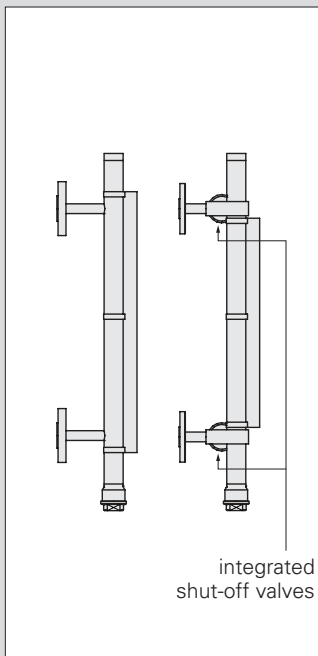

integrated shut-off valves

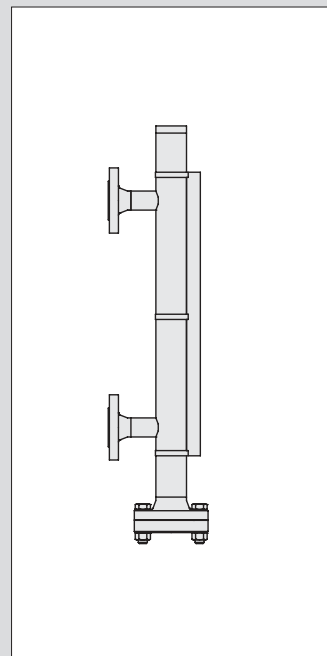
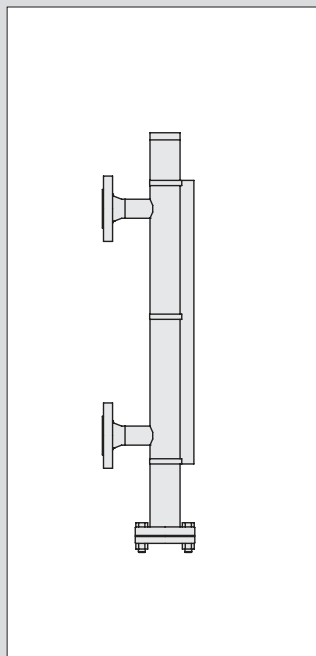
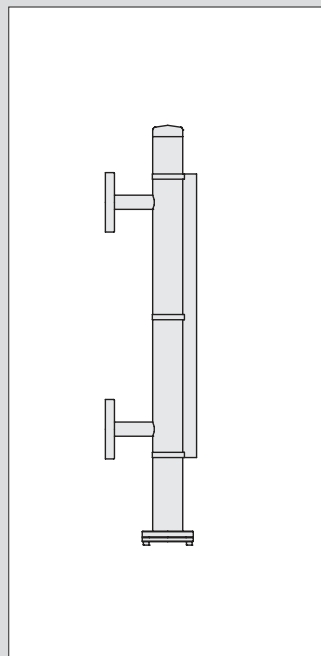

| Smart-Line 50<br>34000/34110 | Standard 6<br>23614                                | Standard 28<br>34300                               | Standard 50<br>32755                               |
|------------------------------|----------------------------------------------------|----------------------------------------------------|----------------------------------------------------|
| A, B, K, O                   | A, B, K, O                                         | A, B, K, O                                         | A, B, K, O                                         |
| up to 50 bar                 | up to 6 bar                                        | up to 28 bar                                       | up to 50 bar                                       |
| -40 up to +250 °C            | -40 up to +150 °C                                  | -40 up to +400 °C                                  | -40 up to +400 °C                                  |
| OD 33.7 mm                   | OD 53 mm                                           | OD 53 mm                                           | OD 54 mm                                           |
| > 0.6 g/cm <sup>3</sup>      | > 0.6 g/cm <sup>3</sup> (> 0.4 g/cm <sup>3</sup> ) | > 0.6 g/cm <sup>3</sup> (> 0.4 g/cm <sup>3</sup> ) | > 0.6 g/cm <sup>3</sup> (> 0.4 g/cm <sup>3</sup> ) |
| max. 150 cSt                 | max. 600 cSt                                       | max. 600 cSt                                       | max. 600 cSt                                       |

### ● Wide range of operating conditions

Operating pressures can be from vacuum to 500 bar. Float chambers are available with design pressures up to 630 bar. Liquid densities > 0.3 g/cm<sup>3</sup> and media temperatures from 77 K to 673 K (-196 °C to +400 °C) allow use for applications like cryogenic liquid gases LPG/LNG, water hydraulics and steam boilers. Closed floats are available for most liquids at pressures up to 350 bar. Open floats are available for non condensating liquids at pressures up to 630 bar.

### ● Energy-free, reliable operation

WEKA VLIs are ideally suited for plant start-up operations. The indication function does not require electrical power. The float principle makes this a direct method of level measurement, with definite level indication. The control functions of a VLI are independent of its display function. Therefore the level is always observable, even if the power supply fails.

### ● Versatility through choice of materials

#### Standard materials

- Stainless steel 316/316L  
1.4404 / 1.4432  
1.4435
- Group A4 austenitic steel

#### Stainless steel materials as option

- 304/304L 1.4301 / 1.4306  
1.4307
- (316Ti) 1.4571
- 321 1.4541

#### Stainless steel with higher molybdenum content, e.g.

- 1.4539 (904L; UNS N08904)
- 254 SMO (UNS 31254)

#### Nickel alloys and special metals, e.g

- Inconel®/Incoloy®/Hastelloy®
- Titanium alloys
- Zirconium and Tantalum
- Aluminum alloys

#### Engineered Plastics

- PVDF, PP, PE, PVC
- ECTFE (Halar) coating
- PTFE-PFA lining
- Teflon-PFA coating

WEKA VLI Level Indicators can be manufactured according to special request in almost any non-magnetic material, subject to physical properties and chemical compatibility.

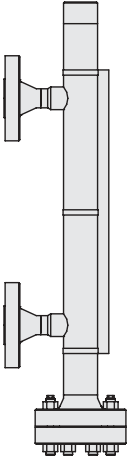
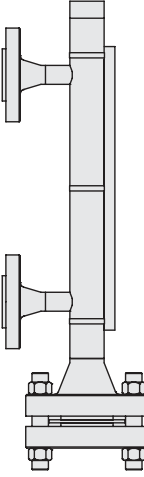
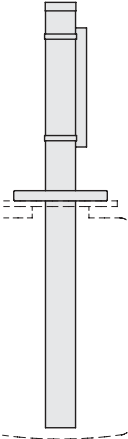
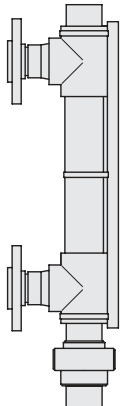

WEKA VLI Smart-Line,  
Type 34000-K

|                                                                                   |                                                                                   |                                                                                    |                                                                                     |
|-----------------------------------------------------------------------------------|-----------------------------------------------------------------------------------|------------------------------------------------------------------------------------|-------------------------------------------------------------------------------------|
|  |  |  |  |
| <b>High Pressure – Power</b>                                                      | <b>Petro</b>                                                                      | <b>Top of Tank</b>                                                                 | <b>Engineered Plastic</b>                                                           |
| <b>Diverse</b>                                                                    | <b>Diverse</b>                                                                    | <b>Diverse</b>                                                                     | <b>Diverse</b>                                                                      |
| A, B, K, O                                                                        | A, B, K, O                                                                        | –                                                                                  | A, B, K, O                                                                          |
| up to 500 bar                                                                     | up to 630 bar                                                                     | up to 50 bar                                                                       | up to 10 bar                                                                        |
| –10 up to +400 °C                                                                 | –80 up to +400 °C                                                                 | –40 up to +400 °C                                                                  | according to material                                                               |
| diverse                                                                           | diverse                                                                           | diverse                                                                            | diverse                                                                             |
| > 0.6 g/cm <sup>3</sup> (> 0.4 g/cm <sup>3</sup> )                                | > 0.3 g/cm <sup>3</sup>                                                           | > 0.4 g/cm <sup>3</sup>                                                            | > 0.6 g/cm <sup>3</sup>                                                             |
| max. 600 cSt                                                                      | max. 600 cSt                                                                      | max. 600 cSt                                                                       | max. 600 cSt                                                                        |

### ● Excellent Readability

The wide colour contrasted indicating flags are easily and clearly readable, even from far distances. The flag elements are normally red and aluminum coloured, but can be optionally ordered with alternative colour combinations. Difficult liquids in corrosive and high/low temperature applications do not effect the reliable functioning of WEKA VLIs, because the liquid inside the float chamber is totally isolated from the indication rail. For the same reason, readability is not impaired by turbid conditions.

### ● Level Measurement à la carte

WEKA VLIs can provide an optimal solution for almost any level measuring and control application. For most applications, a suitable indicator can be configured from standard modular components. Special solutions are frequently needed for unusual operating and installation conditions. Our customers can take advantage of our 40 year experience in manufacturing custom level indicators based on the proven WEKA design of magnetic float and indication rail. We cover an extremely wide range of special level instrumentation require-

ments. If necessary, the standard interfaces can be adapted to match the requirements of customer's control systems. Magnetic flag elements of WEKA VLI indication rails can be supplied with colour combinations other than the standard colours. The WEKA magnet and indication rail system can also be used for position indication of hydraulic and pneumatic cylinder pistons and pressure accumulator diaphragms. WEKA's extensive custom design expertise can produce reliable instrumentation solutions for linear displacement monitoring requirements.

### ● Applications

WEKA has accumulated a wealth of knowledge about design and manufacturing of indicators and sensors for special applications. We have many years of practical experience in the use of WEKA VLI Level Indicators in chemical and other process industries, shipbuilding, thermal power plants, hydraulic systems, railways, vehicular applications, petrochemical industries, and refrigeration systems, to name just a few.



**Petro-VLI – Our solution for your petrochemical applications**

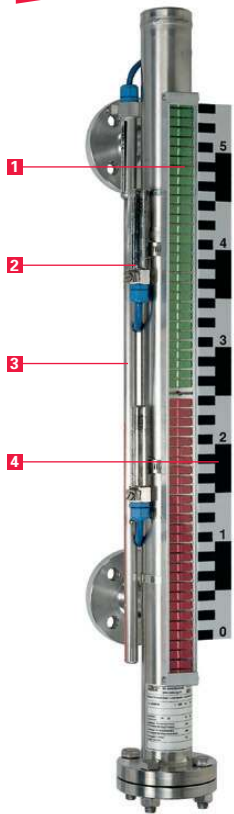

WEKA VLI Standard, Type 34300-K

## 1 Indication Rails

The indication rails of WEKA VLIs are never in contact with the process media, and are consequently maintenance-free. The flags of these indication rails are 36 mm wide, and therefore easily read even from far distances. The lightweight flags are magnetically coupled to each other and respond positively even at float displacement speeds of 2 meters per second. The special design of WEKA VLIs ensures reliable read-out at all times: the flags hold their positions even in the presence of vibration and temperature variations. For outdoor installations, refrigerant applications and food-processing industries we recommend indication rails with a polyolefin protective tube which is more resistant towards aggressive atmospheres, and also prevents ice formation and condensation.

– The standard indication rail is made of polycarbonate. This is suitable for media temperatures ranging from cryogenic to +150 °C, and has a viewing angle of 240°. The profile has stainless steel end-caps. The flags are red and aluminum anodized, but are optionally available with other colour combinations, for example to conform to a process media colour coding scheme.

– For media temperatures up to +250 °C, the rail is made of aluminum and the cover of transparent polycarbonate.

– For media temperatures up to +400 °C, the rail is made of aluminum and the cover of glass. The flags are black and aluminium enamel varnished.



## 2 Magnetic Switches

WEKA VLIs are available with magnetic switches installed at the rear of the float chamber, actuated by the rear field of the bar magnet in the float. These switches add level detection functions to VLIs. The switches may be connected directly to inputs of PLCs or computer-based systems, or through contactors for control of valves or pumps. The magnetic switches are bi-stable: each is latched in one state (open or closed) on the first pass of the float's bar magnet, and reset to the original state on the second (reverse) pass. The magnetic switches are available as on-off (SPST) or changeover (SPDT) types. The stainless steel housings allow them to be used in practically any type of environment, and with media temperatures up to +350 °C.



Magnetic switches are available in various versions

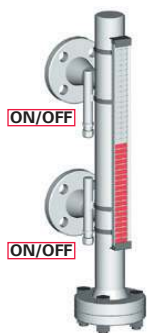

The number of switching points is limited only by the availability of space. Magnetic switch modules are available for use in highly combustible atmospheres: either as intrinsically safe (Ex i) versions or with pressure-tight explosion-proof (Ex d) housings that conform to the European Directive ATEX/IECEX.

## 3 Transmitters

WEKA VLIs are available with an optional electronic transmitter to provide a continuously variable electrical signal that can be fed to a remote level indicator, PID controller, recorder or PLC. This can be in the form of a 3-wire (current or resistance) or 2-wire (current loop) output. These transmitters are available for media temperatures up to +350 °C. A choice of output connections are available: plug-in connector, terminal box, or pre-wired cable lead. Transmitters are optionally available for use in highly combustible atmospheres: either as intrinsically safe (Ex i) versions or with pressure-tight explosion-proof (Ex d) housings that conform to the European Directive ATEX/IECEX.

## 4 Measuring Scales

Measuring scales are available with printed or engraved aluminium dibond or stainless steel scales. The standard scale division is 10 cm: users may optionally order other scale divisions.

Detailed information about the WEKA VLI product range, including accessories, is available at our website [www.weka-ag.ch](http://www.weka-ag.ch).

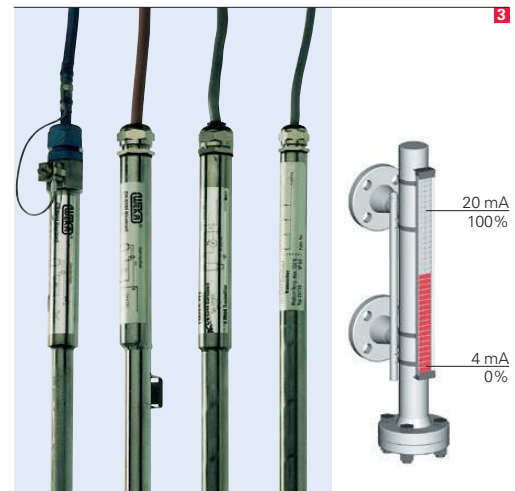

Transmitters make the visual indicator to a level transmitter



Germanischer Lloyd



**Know-How**  
**Quality**  
**Flexibility**



- 1940** Arthur **Welter** and August **Karrer** found **WEKA** GmbH
- 1949** Reorganisation as WEKA AG
- 1950** First WEKA Stainless Steel Valve
- 1962** First patent for the WEKA Visual Level Indicator
- 1978** First WEKA Cryogenic Valve and Coupling
- 1981** WEKA becomes part of IMO/GEMS Group, USA
- 1982** Approval according to the German (AD-HP 0) and Swiss (SVDB501) pressure vessel rules. Audit of first WEKA Quality Control System
- 1991** New facilities in Bäretswil, approx. 25 km South-east of Zurich
- 1995** Integration of the European production of GEMS Tank Level Instruments
- 2001** WEKA joins as member of ARCA group, Germany
- 2002** Audit of TQM System by German Lloyd acc. to ISO 9001 and PED, Module H/H1
- 2003** Approval by Zelm Ex acc. to ATEX
- 2007** WEKA introduces SAP All-in-One for all business processes successfully within short time
- 2009** Approval by Zelm Ex acc. to IECEx

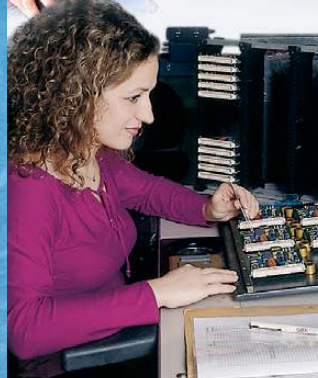

**A member of the ARCA Flow Group:**



Visual Level Indicators



Tank Level Instruments



Visual Level Indicators

Tank Level Instruments

Cryogenic Components

Stainless Steel Valves

MicroFlow Valves

Cryogenic Components

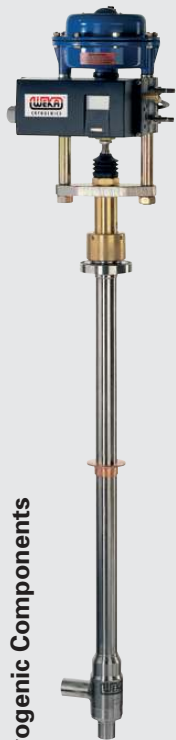

Stainless Steel Valves



MicroFlow Valves



WEKA AG, Schürlistrasse 8  
CH-8344 Bäretswil, Switzerland  
Phone +41 43 833 43 43  
Fax +41 43 833 43 49  
info@weka-ag.ch · www.weka-ag.ch

Your contact for  
WEKA Visual Level Indicators: