



## GENERAL SPECIFICATIONS

### EGM Flowmeter

- Flow Rates: 0.50 GPH - 21.1 GPM (2 L/hr - 80 L/min)
- Sizes: 1/4" - 3/4" (6 mm - 20 mm)
- Engine Power: 7.5HP - 5000HP (Please consult distributor for larger engines)
- Temperature Range: -40°F - +176°F (-40°C - +80°C)
- Body Material: Stainless Steel 316
- Rotor Material: PPS (Stainless Steel 316 for EGM006 meters)
- Cable Length: 2 meters (can extend using cable connector)

### F127 Totalizer

- Casing: Robust IP66/IP67 field enclosure
- Display: 7-digit resettable total, 11-digit accumulated total with backlight
- Required Power Supply: 8 – 24V (dc) (back up power supply built in to save settings in case of power failure)
- Temperature Limit: -40°F - +176°F (-40°C - +80°C)
- Output Options: 4-20mA and pulse output available

## KIT SELECTION

Although each Fuel Consumption Kit consists of the same items, the size of the meter and the process connections change depending on the rate of flow, which is a direct correlation to the size of the engine.

A typical diesel fuel loop system would on average have 3.5 times more fuel in its line than what the engine consumes at full load. With this in mind, selecting the right kit based on the engine's power output is important to ensure accuracy and the positive displacement meters' longevity.

The graphs depicted here should be used as a guide when determining the size of kit is required.

## KIT INCLUDES:

- 2 x EGM-Series Electronic Flowmeter
- 1 x F127 Totalizer
- 2 x Meter Brackets
- 2 x Fuel Strainer plus Connector
- Cable Glands

## FUEL CONSUMPTION SYSTEM - Marine

**FLOMEC<sup>®</sup> Fuel Consumption System (FCS)** is a complete fuel monitoring system that comprises 2x EGM positive displacement meters coupled with an F127 flow instrument for accurate measurement of fuel consumption rates and total fuel consumption. The FCS can accurately measure fuel consumption on combustion engines by correcting for temperature differences from the inlet to outlet of the engine. Pulsating flow electronics, eliminating error due to fuel injection pulsation, coupled with integral PT100 resistance thermometers in Flomec's renowned positive displacement meters gives an accurate and economic fuel consumption measurement solution for all engine sizes.

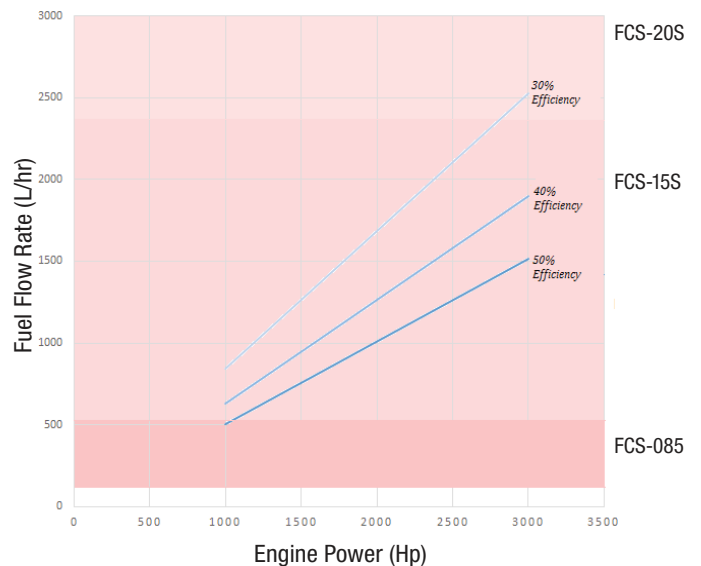
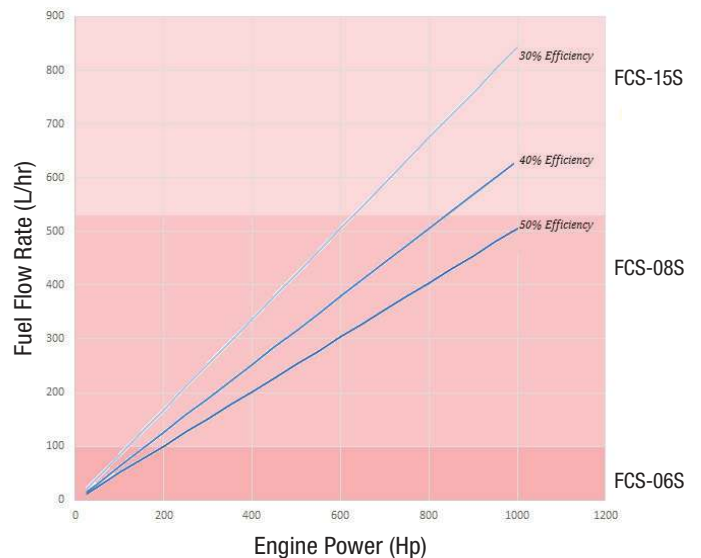

The Fuel Consumption System is designed for Diesel Fuel. Diesel fuel is not considered a flammable fluid in most of the world, but it is in the USA. **The Fuel Consumption System does not have FM Approval and should not be sold for use in the USA.**

## KIT SELECTION (CONTINUED)

	Meter A Specification (Inlet) Size Flow Range			Process Connections	Meter B Specification (Outlet) Size Flow Range		
FCS-06S	1/4" (6 mm)	2-100 L/hr	0.5-27 GPH	NPT Female Thread	1/4" (6 mm)	2-100 L/hr	0.5-27 GPH
FCS-08S	3/8" (8 mm)	15-550 L/hr	4-145 GPH	NPT Female Thread	3/8" (8 mm)	15-550 L/hr	4-145 GPH
FCS-15S	1/2" (15 mm)	1-40 L/hr	0.26-10.6 GPH	NPT Female Thread	1/2" (15 mm)	1-40 L/hr	0.26-10.6 GPH
FCS-20S	3/4" (20 mm)	3-80 L/hr	0.5-21 GPH	NPT Female Thread	3/4" (20 mm)	3-80 L/hr	0.5-21 GPH

## DIMENSIONS

EGM  
Flow Meter

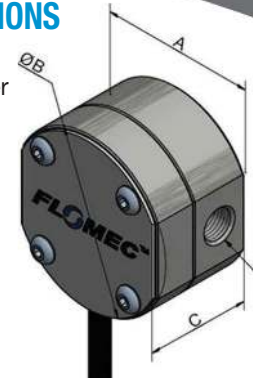

## ACCESSORIES

Part Number	Item	Description
1522056	F-Series Wall Mount Kit	Stainless Steel wall mount kit for F127 totalizer, screws included
1522052	F-Series Pipe Mount Kit	Stainless Steel wall pipe kit for F127 totalizer, excludes worm clamps
1522063	Worm Clamp Kit 1.0-1.57" (25-40 mm)	Includes 2pcs of stainless steel worm clamps to suit #1522052 and pipe. OD from 1.0-1.57" (25-40 mm)
1522055	Worm Clamp Kit 1.81-2.76" (46-70 mm)	Includes 2pcs of stainless steel worm clamps to suit #1522052 and pipe. OD from 1.81-2.76" (46-70 mm)
1519011	M16 Cable Gland	Includes cable gland, locking nut and o-ring
1519012	M20 Cable Gland	Includes cable gland, locking nut and o-ring
1519010	Cable Connector	7-Pin IP67 Polyamide connector kit

Model:	A	B	C
EGM006	2.28" (58 mm)	2.54" (64.5 mm)	1.54" (39 mm)
EGM008	2.28" (58 mm)	2.54" (64.5 mm)	1.93" (49 mm)
EGM015	2.84" (72 mm)	3.23" (82 mm)	2.60" (66 mm)
EGM020	2.84" (72 mm)	3.23" (82 mm)	3.03" (77 mm)

## SCHEMATIC

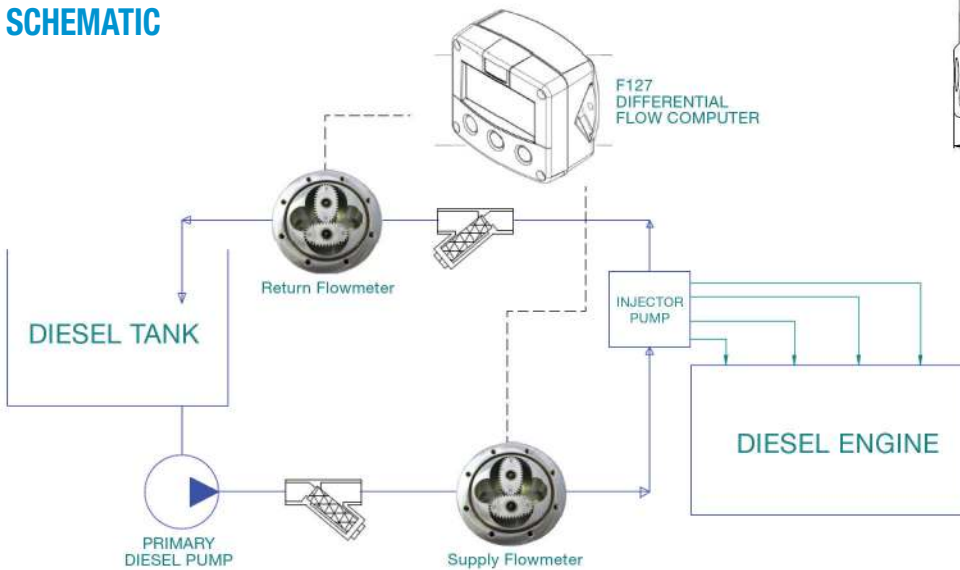

## F127 Totalizer

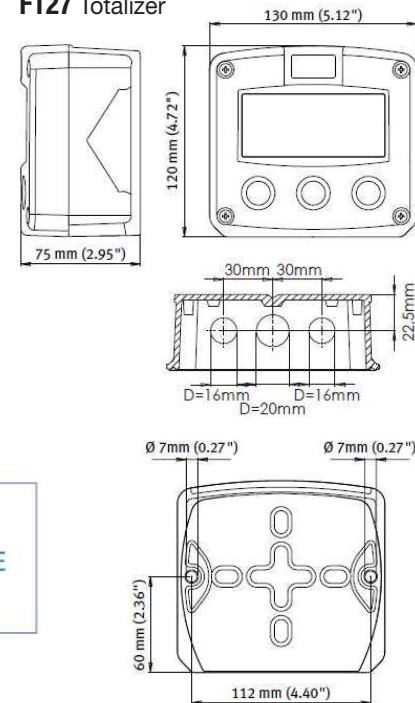

 **Not Available in the U.S.A.**

**Service & Warranty:** For technical assistance, warranty replacement or repair contact your **FLOMEC®** or **GPI®** distributor:

In North or South America: **888-996-3837 / FLOMEC.net**

Outside North or South America: **+61 2 9540 4433 / FLOMEC.net**

Wichita · Sydney · Mexico City

GREAT PLAINS INDUSTRIES 