

**LAUMAS**<sup>®</sup>  
ELETTRONICA

CATALOGO **N. 27**  
CATALOG

**SISTEMI DI PESATURA E DOSAGGIO**  
*WEIGHING AND BATCHING SYSTEMS*



**02**

**BILANCE, MODULI E PIATTAFORME DI PESATURA**  
*SCALES, MODULES AND WEIGHING PLATFORMS*

**02.1** **Bilance contapezzi**  
*Counting scales*

**02.4** **Piattaforme di pesatura**  
*Weighing platforms*

**02.2** **Mini bilance tascabili**  
*Pocket mini scales*

**02.5** **Pesa pallet**  
*Pallet-weighing*

**02.3** **Dinamometri**  
*Crane scales*

**02.6** **Barre pesatrici**  
*Weighing bars*

## 02.1

## Bilance contapezzi

### Counting scales

	modello model	portata kg capacity kg	pagina page
	<b>LACSN</b>	6, 15, 30	<b>4</b>
	<b>BIL</b>	3, 6, 15, 30	<b>5</b>
	<b>BIL2B</b>	6, 15, 30	<b>7</b>

## 02.2

## Mini bilance tascabili

### Pocket mini scales

	modello model	portata kg capacity kg	pagina page
	<b>LBIL 500</b>	0.5	<b>9</b>
	<b>LBIL 3000</b>	3	<b>9</b>

## 02.3

## Dinamometri





### Crane scales

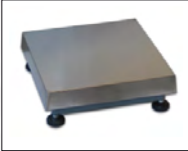

	modello model	portata kg capacity kg	pagina page		modello model	portata kg capacity kg	pagina page
	<b>DTEP</b>	50, 150, 300	<b>10</b>		<b>DTER</b>	3000, 5000	<b>12</b>
	<b>DTEN</b>	500, 1000, 3000, 5000, 10000, 20000	<b>11</b>		<b>DTEZ</b>	3000, 5000, 10000, 20000, 30000	<b>13</b>
					<b>DTE30</b>	30000	<b>14</b>

## 02.4

## Piattaforme di pesatura

### Weighing platforms

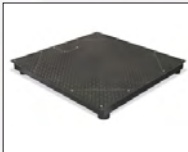
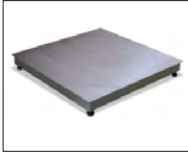

modello model	portata kg capacity kg	dimensioni mm dimensions mm	pagina page
 <b>ACN</b>	6, 15, 30, 50 60, 120 150, 300 600	300 x 300 400 x 400 600 x 600 800 x 800	<b>15</b>
 <b>AIN</b>	6, 15, 30, 50 60, 120 150, 300 600	300 x 300 400 x 400 600 x 600 800 x 800	<b>16</b>
 <b>AILN</b>	15, 30, 60, 150 200, 300	400 x 400 600 x 600	<b>17</b>
 <b>MN</b>	75, 150, 300	460 x 600	<b>18</b>

modello model	portata kg capacity kg	dimensioni mm dimensions mm	pagina page
 <b>P_S5</b>	1500 1500 1500	1250 x 1250 1200 x 1500 1500 x 1500	<b>19</b>
 <b>P</b>	3000 3000 3000	1250 x 1250 1200 x 1500 1500 x 1500	<b>20</b>
 <b>P-INOXN_S5</b>	1500 1500	1250 x 1250 1500 x 1500	<b>21</b>
<b>P-INOXN</b>	3000 3000	1250 x 1250 1500 x 1500	<b>22</b>
<b>PM</b>	1000	1200 x 1600 H min. 100	<b>23</b>

## 02.5

## Pesa pallet

### Pallet-weighing

modello model	portata kg capacity kg	dimensioni mm dimensions mm	pagina page
 <b>PX</b>	3000	1250 x 840 H min. 95	<b>24</b>
 <b>PXI</b>	3000	1250 x 840 H min. 95	<b>24</b>

## 02.6

## Barre pesatrici

### Weighing bars

modello model	portata kg capacity kg	pagina page
 <b>BARRAC1250</b>	1500	<b>25</b>

LACSN 6 kg.....0.2 g **divisione / division**.....  
 LACSN 15 kg.....0.5 g **divisione / division**.....  
 LACSN 30 kg.....1 g **divisione / division**.....

**OPZIONI A RICHIESTA :**

- TARATURA con CERTIFICATO DI RIFERIBILITÀ SIT .....

**OPTIONS ON REQUEST :**

- Calibration with SIT traceability certificate .....



- **DIMENSIONI 320 x 335 x h 113 (max 123) mm**
- **STRUTTURA IN MATERIALE PLASTICO**
- **PIANO DI CARICO IN ACCIAIO INOX 230 x 335 mm**
- **CELLA DI CARICO OFF-CENTER IN ALLUMINIO**
- DIMENSIONS 320 x 335 x h 113 (max 123) mm
- PLASTIC STRUCTURE
- STAINLESS STEEL LOADING TOP 230x335 mm
- SINGLE-POINT ALUMINUM LOAD CELL

Dimensions (mm)

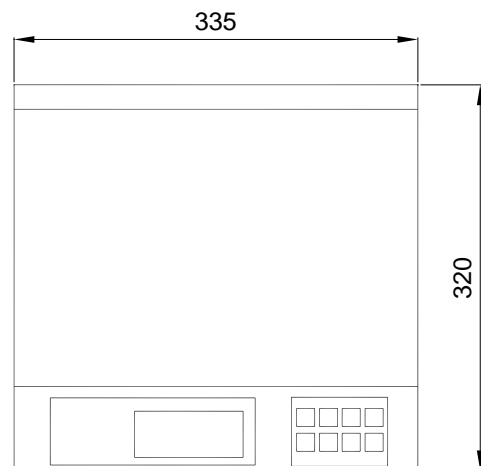
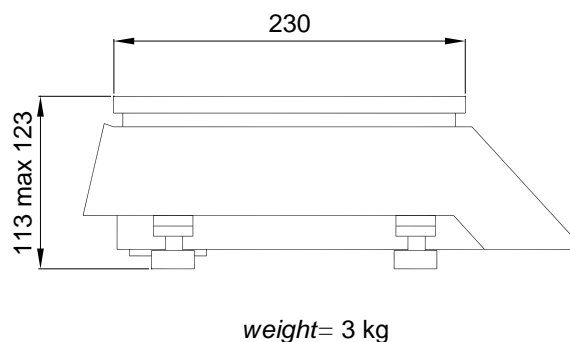

- Funzione contapezzi.
- Funzione peso in percentuale (%).
- Funzione controllo peso con segnalazione acustica in relazione a 2 soglie impostabili.
- Uscita RS232 per collegamento a PC.
- Display LCD retroilluminato a 6 digit da 30mm, 7 segmenti.
- Tastiera impermeabile con 8 tasti funzione.
- Alimentazione mediante batteria interna ricaricabile 4V 4Ah. Carica batteria esterno 230 Vca in dotazione.
- Piedini regolabili. Bolla di livello.
- Counting function.
- Percentage weight % function.
- Checking weight by acoustic alarm (two thresholds programmable).
- RS232 output for connection to PC.
- Six-digit backlit LCD display (30 mm), 7 segment
- 8-Key impermeable keyboard.
- Power supply with rechargeable internal battery 4V 4Ah for LACS-N version. Power supply cable 230Vca for recharge battery.
- Adjustable feet. Bubble level.

<b>BIL6</b>	<b>max 6 kg</b>	<b>0.1 g divisione / division</b> (ad uso interno di fabbrica / for internal use only) . . .
<b>BIL15</b>	<b>max 15 kg</b>	<b>0.2 g divisione / division</b> (ad uso interno di fabbrica / for internal use only) . . .
<b>BIL30</b>	<b>max 30 kg</b>	<b>0.5 g divisione / division</b> (ad uso interno di fabbrica / for internal use only) . . .
* <b>VERIBIL6</b>	<b>max 3/6 kg</b>	<b>1/2 g divisione / division</b> (omologata CE-M per uso legale / legal for trade use)
* <b>VERIBIL15</b>	<b>max 6/15 kg</b>	<b>2/5 g divisione / division</b> (omologata CE-M per uso legale / legal for trade use)
* <b>VERIBIL30</b>	<b>max 15/30 kg</b>	<b>5/10 g divisione / division</b> (omologata CE-M per uso legale / legal for trade use)
<b>OPZIONI A RICHIESTA :</b>		<b>OPTIONS ON REQUEST :</b>
- <b>BATTERIA6V4AH</b> batteria ricaricabile Panasonic mod. LC-R064R5P-6 V, 4.5 Ah . . . . .		- <b>BATTERIA6V4AH</b> Panasonic rechargeable battery mod. LC-R064R5P - 6 V, 4.5 Ah . . . . .
- <b>TARATURA con CERTIFICATO DI RIFERIBILITÀ SIT</b> . . . . .		- <b>Calibration with SIT traceability certificate</b> . . . . .
- <b>PIATTOBAC</b> piatto a bacinella INOX 230 x 300 x h 40 mm . . . . .		- <b>PIATTOBAC</b> stainless steel deep tray 230 x 300 x h 40 mm . .
- <b>STAVTII</b> stampante termica da tavolo con orologio/calendario . . . . .		- <b>STAVTII</b> desk thermal printer with real-time clock . . . . .
- <b>CARTASTAVT</b> rotolo carta termica (larghezza 57,5 mm; lunghezza 15 m; diametro esterno 40 mm) . . . . .		- <b>CARTASTAVT</b> thermal paper roll (width 57.5 mm; length 15 m; outside diameter 40 mm) . . . . .
- <b>CARTAFISCADE</b> rotolo carta termica adesiva (larghezza 57,5 mm; lunghezza 15 m; diametro esterno 50 mm) . . . . .		- <b>CARTAFISCADE</b> thermal adhesive paper roll (width 57.5 mm; length 15 m; outside diameter 50 mm) . . . . .

- \* **Versioni OMOLOGATE CEM** fornite con sigillo metrico (Verificazione prima)
- \* **CEM APPROVED versions** equipped with metric seal (Initial Verification)



\* **VERSIONI PER USO LEGALE  
IN RAPPORTO CON TERZI**  
( Legal for trade use )

### Funzioni principali

- Funzione Contapezzi con visualizzazione in sequenza del numero dei pezzi, peso unitario medio di ogni singolo pezzo, peso complessivo dei pezzi presenti in bilancia.
- Uscita RS232 per collegamento a PC o stampante da tavolo STAVTII per stampa Logo o intestazione cliente, data, ora, peso netto, peso unitario medio, n° dei pezzi, totale pesi e totale n° dei pezzi.
- Retroilluminazione display.
- Totalizzazione automatica o manuale delle pesate.
- Indicatore di peso in percentuale %.
- Funzione Controllo peso/pezzi/percentuale con segnalazione acustica e visiva in relazione a 2 soglie impostabili.
- Autospegnimento automatico impostabile (risparmio energetico).
- Variazione unità di misura da kg a g.

### Main Functions

- Counting function with displaying in sequence the number of pieces, the average unit weight of each piece, total weight of the pieces.
- RS232 Output for connection to PC or impact printer series STAVTII to print customer Logo or header, date, time, net weight, average unit weight, No. of pieces, total weight, Total number of pieces.
- Display backlight command.
- Automatic / manual totalization of weighings.
- Weight in percentage %.
- Check of weight / pieces / percentage by visual and acoustic alarms with two thresholds programmable.
- Automatic shutdown programmable (energy saving).
- Possibility to change the unit of measurement: kg to g.

STAVTII



PIATTOBAC



### Caratteristiche :

Display LCD retroilluminato a 6 cifre da 24 mm, 7 segmenti. Tastiera impermeabile con 7 tasti multifunzione.  
 Piatto in acciaio inox 225 x 295 mm.  
 Copertina plastica di protezione.  
 Alimentazione: Batteria interna ricaricabile 6V 4Ah (70 ore autonomia) provvista di carica batteria esterno 230Vca.  
 Piedini regolabili per regolazione bolla di livello.  
 Manuale cartaceo di installazione-uso compreso nella fornitura.

### Features :

Backlit LCD display with 6 digits (24 mm high), 7 segment.  
 7-key impermeable keypad.  
 Stainless steel plate 225 x 295 mm.  
 Plastic protection cover.  
 Power supply: rechargeable internal battery 6V 4Ah (70-hour operating time) with 230VAC power adapter included to recharge battery.  
 Feet adjustable and bubble level.  
 Printed user's manual included in the supply.

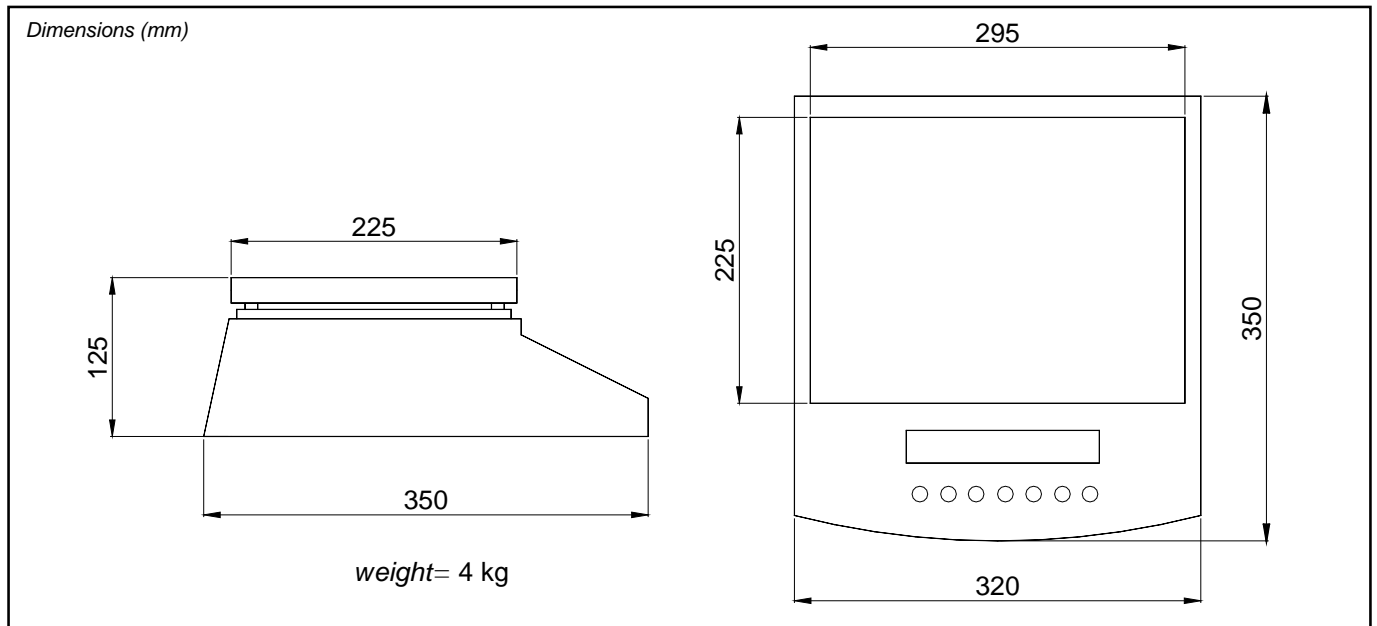

### STAMPA DEI PESI TOTALIZZATI : (PRINTOUT OF TOTALIZATION OF WEIGHTS)

primo articolo totalizzato / first item

	<b>Bulloneria Bianchi</b>	
16:29	22-05-09	
GS	2000 g	( peso lordo/netto / gross/net weight )
No.	1	
Total	2,000 kg	( peso totale / total weight )

secondo articolo totalizzato / second item

16:59	22-05-09	
GS	1000 g	( peso lordo/netto / gross/net weight )
No.	2	
Total	3,000 kg	( peso totale / total weight )

### STAMPA DEI PEZZI TOTALIZZATI : (PRINTOUT OF TOTALIZATION OF PIECES)

primo articolo totalizzato / first item

	<b>Bulloneria Bianchi</b>	
16:29	22-05-09	
GS	4000 g	( peso lordo/netto / gross/net weight )
U.W.	99,9447 g/p	( peso medio unitario / average unit weight )
PCS	40pcs	( n° pezzi / No of pieces )
No.	1	
Total	40pcs	( totale pezzi / Total of pieces )

secondo articolo totalizzato / second item

16:59	22-05-09	
GS	4000 g	( peso lordo/netto / gross/net weight )
U.W.	99,9447 g/p	( peso medio unitario / average unit weight )
PCS	40pcs	( n° pezzi / No of pieces )
No.	2	
Total	80pcs	( totale pezzi / Total of pieces )

<b>BIL2B6</b>	max 6 kg .....	<b>0.1 g</b> divisione / division.....
<b>BIL2B15</b>	max 15 kg .....	<b>0.2 g</b> divisione / division.....
<b>BIL2B30</b>	max 30 kg .....	<b>0.5 g</b> divisione / division.....

**OPZIONI A RICHIESTA :**

- **BATTERIA6V4AH** batteria ricaricabile Panasonic mod. LC-R064R5P-6 V, 4.5 Ah .....
- **TARATURA con CERTIFICATO DI RIFERIBILITÀ SIT** .....
- **PIATTOBAC** piatto a bacinella INOX 230 x 300 x h 40 mm .....
- **STAVTII** stampante termica da tavolo con orologio/calendario .....
- **CARTASTAVT** rotolo carta termica (larghezza 57,5 mm; lunghezza 15 m; diametro esterno 40 mm) .....
- **CARTAFISCADE** rotolo carta termica adesiva (larghezza 57,5 mm; lunghezza 15 m; diametro esterno 50 mm) .....

**OPTIONS ON REQUEST :**

- **BATTERIA6V4AH** Panasonic rechargeable battery mod. LC-R064R5P - 6 V, 4.5 Ah .....
- Calibration with SIT traceability certificate .....
- **PIATTOBAC** stainless steel deep tray 230 x 300 x h 40 mm .....
- **STAVTII** desk thermal printer with real-time clock .....
- **CARTASTAVT** thermal paper roll (width 57.5 mm; length 15 m; outside diameter 40 mm) .....
- **CARTAFISCADE** thermal adhesive paper roll (width 57.5 mm; length 15 m; outside diameter 50 mm) .....



**CON INGRESSO PER  
 SECONDA PIATTAFORMA  
 CONNECTABLE TO  
 A REMOTE PLATFORM**

**Esempio di applicazione con piattaforma remota**  
 Example of application with remote platform



Dettagli piattaforme in abbinamento vedi pag. 23-24  
 (see details pages 23-24 for combined platforms)

**Funzioni principali**

- Ingresso per seconda piattaforma di pesatura (remota).
- Funzione Contapezzi operativa anche sulla seconda piattaforma; normalmente si esegue il campionamento dei pezzi sulla bilancia BIL2B e il conteggio delle grandi quantità sulla piattaforma remota (a scelta tra la ns gamma).
- Memorizzazione di max 100 articoli (PLU), per ogni articolo è possibile memorizzare e richiamare: descrizione alfanumerica (nome), valore di tara predeterminata, peso medio unitario calcolabile da campionamento automatico o impostabile da tastiera.
- Visualizzazione in contemporanea del numero dei pezzi, peso unitario medio di ogni singolo pezzo, peso complessivo dei pezzi presenti in bilancia.
- Uscita RS232 per collegamento a PC o stampante: PC (in continuo / bidirezionale) : impostazione PLU, comando di azzeramento, lettura ID bilancia, peso netto, peso lordo, totalizzazione pezzi, ect.  
 Stampante da tavolo STAVTII: stampa Logo o intestazione Cliente, data, ora, nome articolo, ID bilancia, tipo bilancia, peso netto, peso unitario medio, n° dei pezzi, totale pesi e totale n° dei pezzi.
- Retroilluminazione display.
- Totalizzazione automatica o manuale delle pesate.
- Funzione Controllo peso/pezzi/percentuale con segnalazione acustica e visiva in relazione a 2 soglie impostabili.
- Autospegnimento automatico impostabile (risparmio energetico).

**Main Functions**

- Input for connection to a remote weighing platform.
- Counting function (also on remote weighing platform); normally the operator performs the sampling of the pieces on the BIL2B and counting large quantities on the remote platform (choose between our range).
- Storing up to 100 items (PLU memories), for each item you can store and recall form keypad: alphanumeric description (name), preset tare value, average unit weight calculated by automatic sampling or programmable by keypad.
- Simultaneous displaying of the number of pieces, the average unit weight of each piece, total weight of the pieces.
- RS232 output for connection to PC or printer:  
 PC (continuous/bidirectional): setting PLU, zero-setting command, reading ID scale, net weight, gross weight, totalizing pieces, ect.  
 Printer mod. STAVTII: customer Logo or header, date, time, item name, ID scale, scale type, net weight, average unit price, number of pieces, total weight, total number of pieces.
- Display backlight command.
- Automatic / manual totalization of weighing.
- Check of weight / pieces / percentage by visual and acoustic alarms with two thresholds programmable.
- Automatic shutdown programmable (energy saving).

**STAVTII**



**PIATTOBAC**



### Caratteristiche :

3 Display LCD retroilluminati, a 6 cifre da 20 mm, 7 segmenti. Tastiera impermeabile con 20 tasti multifunzione.  
 Piatto in acciaio inox 225 x 295 mm.  
 Copertina plastica di protezione.  
 Alimentazione: Batteria interna ricaricabile 6V 4Ah (70 ore autonomia) provvista di carica batteria esterno 230Vca.  
 Piedini regolabili per regolazione bolla di livello.  
 Manuale cartaceo di installazione-uso compreso nella fornitura.

### Features :

3 backlit LCD displays with 6 digits (20 mm high), 7 segment.  
 20-key impermeable keypad.  
 Stainless steel plate 225 x 295 mm.  
 Plastic protection cover.  
 Power supply: rechargeable internal battery 6V 4Ah (70-hour operating time) with 230VAC power adapter included to recharge battery.  
 Feet adjustable and bubble level.  
 Printed user's manual included in the supply.

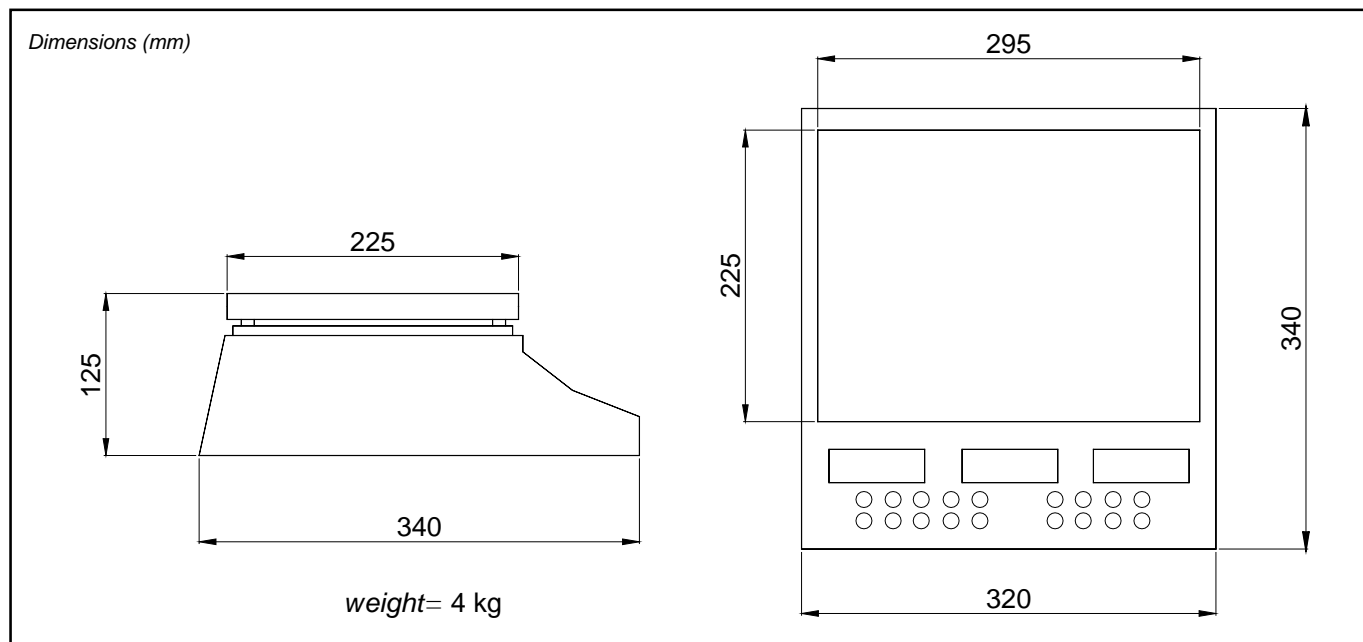

### STAMPA DELLE PESATE E DEI TOTALI: (PRINTOUT OF WEIGHINGS AND TOTAL)

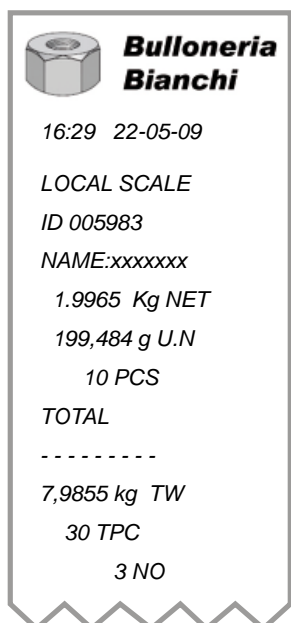

( bilancia locale )

( n° identificazione / identification number )

( nome prodotto / product name )

( peso netto / net weight )

( peso medio unitario / average unit weight )

( n° pezzi / No of pieces )

( totale peso / total weight )

( totale pezzi / total of pieces )

### STAMPA DEI TOTALI: (PRINTOUT OF TOTAL)

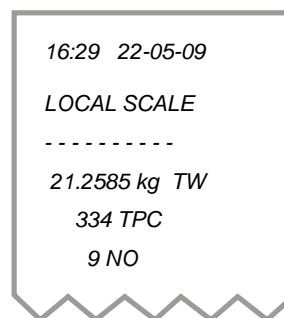

( bilancia locale )

( totale peso / total weight )

( totale pezzi / total of pieces )



**LBIL 500 g** ..... **0.05 g** divisione / division .....

**OPZIONI A RICHIESTA :**

**OPTIONS ON REQUEST :**

- **TARATURA con CERTIFICATO DI RIFERIBILITÀ SIT** ..... - Calibration with SIT traceability certificate .....



- **DIMENSIONI 110 x 72 x h 16,6 mm**
- **PIANO DI CARICO IN ACCIAIO INOX 60 x 60 mm**
- **STRUTTURA IN MATERIALE PLASTICO CON COPERCHIO DI PROTEZIONE**
- DIMENSIONS 110 x 72 x h 16.6 mm
- STAINLESS STEEL LOADING TOP 60 x 60 mm
- PLASTIC STRUCTURE WITH PROTECTION COVER

- Mini bilance tascabili con coperchio di protezione.
- Display LCD blu a 5 digit da 14 mm, 7 segmenti, con funzione retroilluminazione.
- Funzione azzeramento della tara.
- Tastiera impermeabile con 3 tasti funzione.
- Alimentazione: due batterie tipo AAA da 1,5 V (150 ore di autonomia).
- Temperatura di lavoro -10 °C + 40 °C.
- Protezione contro i sovraccarichi.
- Peso bilancia 130 g.

- Pocket mini scales with protection cover.
- Five-digit blue backlit LCD display (14 mm), 7 segment.
- Tare zero-setting function.
- Three-key impermeable keyboard.
- Power supply: two batteries 1.5V type AAA (150-hour operating time).
- Operating temperature -10 °C + 40 °C.
- Overload protection.
- Weight 130 g.

**LBIL 3 kg** ..... **0.1 g** divisione / division .....

**OPZIONI A RICHIESTA :**

**OPTIONS ON REQUEST :**

- **TARATURA con CERTIFICATO DI RIFERIBILITÀ SIT** ..... - Calibration with SIT traceability certificate .....



- **DIMENSIONI 133 x 95 x h 33 mm**
- **PIANO DI CARICO IN ACCIAIO INOX 84 x 68 mm**
- **STRUTTURA IN MATERIALE PLASTICO CON COPERCHIO DI PROTEZIONE**
- DIMENSIONS 133 x 95 x h 33 mm
- STAINLESS STEEL LOADING TOP 84 x 68 mm
- PLASTIC STRUCTURE WITH PROTECTION COVER

- Mini bilance tascabili con coperchio di protezione.
- Display LCD blu a 5 digit da 14 mm, 7 segmenti, con funzione retroilluminazione.
- Funzione azzeramento della tara.
- Tastiera con 4 tasti funzione.
- Alimentazione: quattro batterie tipo AAA da 1,5 V (150 ore di autonomia).
- Temperatura di lavoro -10 °C + 40 °C.
- Protezione contro i sovraccarichi.
- Peso bilancia 320 g.

- Pocket mini scales with protection cover.
- Five-digit blue backlit LCD display (14 mm), 7 segment.
- Tare zero-setting function.
- Four-key keyboard.
- Power supply: four batteries 1.5V type AAA (150-hour operating time).
- Operating temperature -10 °C + 40 °C.
- Overload protection.
- Weight 320 g.

<b>DTEP50</b>	<b>50 kg portata max. / nominal load</b> .....	<b>0.01 kg divisione / division</b> .....
<b>DTEP150</b>	<b>150 kg portata max. / nominal load</b> .....	<b>0.02 kg divisione / division</b> .....
<b>DTEP300</b>	<b>300 kg portata max. / nominal load</b> .....	<b>0.05 kg divisione / division</b> .....

**OPZIONI A RICHIESTA :**

- TARATURA con CERTIFICATO DI RIFERIBILITÀ SIT .....

**OPTIONS ON REQUEST :**

- Calibration with SIT traceability certificate .....



Grillo girevole  
(Swivel shackle)

Gancio girevole  
(Swivel hook)

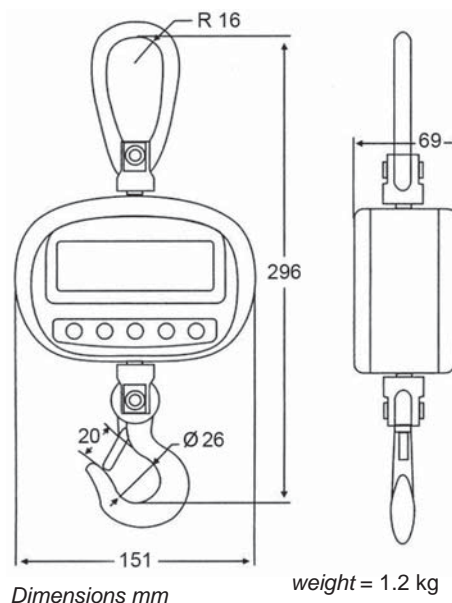

Dimensions mm

weight = 1.2 kg

- Dinamometro digitale ultraleggero completo di grillo e gancio girevoli.
- Cella di carico estensimetrica.
- Grillo superiore e gancio inferiore girevoli.
- Display LCD retroilluminato, a 5 digit da 20 mm.
- Custodia in ABS.
- Alimentazione: 4 batterie AA 1.5V, autonomia di circa 80 ore di funzionamento continuato.
- Spegnimento automatico dopo 30 minuti di inutilizzo.
- Segnalatore acustico peso stabile.

- TELECOMANDO fino a 10 m di distanza con le seguenti funzioni:

- Azzeramento della tara (peso netto)
- Modifica delle divisione di lettura
- Attivazione retroilluminazione display
- Spegnimento

- Ultra-light crane scale with swivel shackle and swivel hook.

- Strain gauge load cell.
- Top swivel shackle and bottom swivel hook.
- Five-digit LCD backlighting display (20 mm high).
- ABS plastic case.
- Power supply: 4 batteries AA 1.5V, 80-hour operating time of continuous functioning.
- Automatic shutdown after 30 minutes.
- Steady-state alarm (beep) enabled.

- REMOTE-CONTROL (max distance 10 m) with following functions:

- Tare zero-setting (net weight)
- Changing the reading division
- Backlight enabling.
- Turning off

### CARATTERISTICHE TECNICHE

CLASSE DI PRECISIONE (% sul Fondo Scala)  
GRADO DI PROTEZIONE  
CARICO STATICO MASSIMO (% sul Fondo Scala)  
CARICO DI ROTTURA (% sul Fondo Scala)  
TEMPERATURA DI ESERCIZIO  
UMIDITA' NON CONDENSANTE

+/- 0.05 % Full Scale  
IP 54  
150 % F.S.  
200 % F.S.  
-10 / +40°C  
10 - 90 %

### TECHNICAL FEATURES

ACCURACY CLASS (% of Full Scale)  
PROTECTION RATING  
SAFE OVERLOAD (% of Full Scale)  
ULTIMATE OVERLOAD (% of Full Scale)  
OPERATING TEMPERATURE RANGE  
HUMIDITY (condensate free)

<b>DTEN500</b>	<b>500 kg portata max. / nominal load</b> .....	<b>0.1 kg divisione / division</b> .....
<b>DTEN1</b>	<b>1000 kg portata max. / nominal load</b> .....	<b>0.2 kg divisione / division</b> .....
<b>DTEN3<sup>(3)</sup></b>	<b>3000 kg portata max. / nominal load</b> .....	<b>0.5 kg divisione / division</b> .....
<b>DTEN5<sup>(4)</sup></b>	<b>5000 kg portata max. / nominal load</b> .....	<b>1 kg divisione / division</b> .....
<b>DTEN10</b>	<b>10000 kg portata max. / nominal load</b> .....	<b>2 kg divisione / division</b> .....
<b>DTEN20</b>	<b>20000 kg portata max. / nominal load</b> .....	<b>5 kg divisione / division</b> .....

**OPZIONI A RICHIESTA :**

- TARATURA con CERTIFICATO DI RIFERIBILITÀ SIT .....

**OPTIONS ON REQUEST :**

- Calibration with SIT traceability certificate .....

(3) - GANCIO3TGIR gancio girevole per DTEN3 .....

(3) - GANCIO3TGIR swivel hook for DTEN3 .....

(4) - GANCIO5TGIR gancio girevole per DTEN5 .....

(4) - GANCIO5TGIR swivel hook for DTEN5 .....

**DTEN500  
DTEN1**



**Gancio girevole  
(Swivel hook)**

mm	DTEN500	DTEN1
<b>A</b>	360	375
<b>B</b>	85	85
<b>C</b>	25	25
<b>Weight</b>	4.5 kg	4.5 kg

Dimensions mm

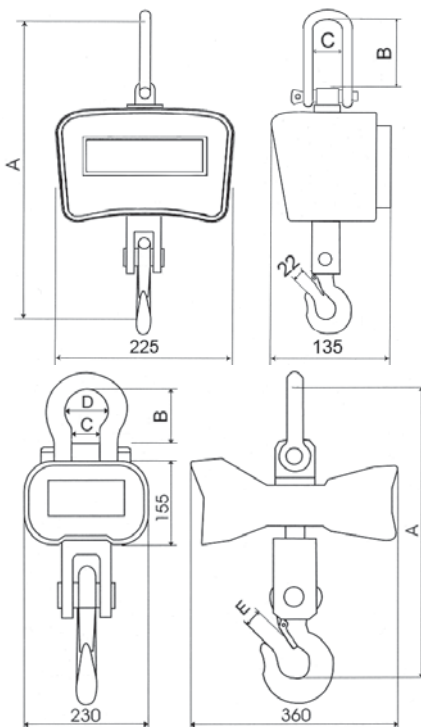

**DTEN3  
DTEN5  
DTEN10  
DTEN20**

mm	DTEN3	DTEN5	DTEN10	DTEN20
<b>A</b>	500	590	750	950
<b>B</b>	92	112	130	220
<b>C</b>	41	58	60	80
<b>D</b>	74	90	95	140
<b>E</b>	32	35	55	75
<b>Weight</b>	16 kg	25 kg	38 kg	63 kg

E = apertura gancio / hook opening

- Dinamometro completo di grillo e gancio (girevole per DTEN500-1).
- Display a Led rossi alta luminosità 5 digit da 30 mm.
- Telecomando fino a 10 metri di distanza.
- Custodia in alluminio pressofuso.
- Alimentazione con batteria interna ricaricabile; alimentatore 230Vca/9Vcc per ricarica batteria. Batteria da 6V 5Ah per DTEN500-1 (autonomia di circa 80 ore di funzionamento continuato); batteria da 6V 10Ah per DTEN3-5-10-20 (autonomia di circa 140 ore funz. contin.).
- Funzione HOLD (blocco del peso visualizzato).
- Totalizzazione delle singole pesate e totale pesate.
- Impostazione tara predeterminata (nota).
- Indicazione del peso netto/lordo.

- Crane scale with shackle and hook (swivel for DTEN500-1)
- Five-digit red LED display (30 mm high).
- Remote-Control (distance max 10 m).
- Die-casting aluminium case.
- Power supply with internal rechargeable; power adapter 230VAC/9VDC to recharge battery. 6V 5Ah battery for DTEN500-1 (autonomy: 80-hour operating time of continuous functioning); 6V 10Ah battery for DTEN3-5-10-20 (autonomy: 140-hour operating time of continuous functioning).
- HOLD function (block of the displayed weight).
- Individual weighing and weights totalization.
- Predetermined tare function.
- Net weight and gross indicator.

### CARATTERISTICHE TECNICHE

CLASSE DI PRECISIONE (% sul Fondo Scala)  
GRADO DI PROTEZIONE  
MAX LETTURE AL SECONDO  
CARICO STATICO MASSIMO (% sul Fondo Scala)  
CARICO DI ROTTURA (% sul Fondo Scala)  
TEMPERATURA DI ESERCIZIO  
UMIDITA' NON CONDENSANTE

+/- 0.03 % Full Scale  
IP 64  
10  
150 % F.S.  
400 % F.S.  
-10°C / +40°C  
10 - 90 %

### TECHNICAL FEATURES

ACCURACY CLASS (% of Full Scale)  
PROTECTION RATING  
MAX READINGS PER SECOND  
SAFE OVERLOAD (% of Full Scale)  
ULTIMATE OVERLOAD (% of Full Scale)  
OPERATING TEMPERATURE RANGE  
HUMIDITY (condensate free)

**IDONEI PER  
CARRIPONTE  
SUITABLE FOR  
BRIDGE CRANES**

**DINAMOMETRO DIGITALE MULTIFUNZIONE  
MULTIFUNCTION CRANE SCALE**

**DTER**

**DTER3** 3000 kg portata max. / nominal load ..... **0.5 kg** divisione / division.....  
**DTER5** 5000 kg portata max. / nominal load ..... **1 kg** divisione / division.....

**OPZIONI A RICHIESTA :**

**OPTIONS ON REQUEST :**

- TARATURA con CERTIFICATO DI RIFERIBILITÀ SIT ..... - Calibration with SIT traceability certificate .....



**DTER3  
DTER5**

**Gancio girevole  
(Swivel hook)**

**VERSIONE  
COMPATTA E LEGGERA  
(COMPACT AND  
LIGHTWEIGHT VERSION)**

mm	DTER3	DTER5
A	70	85
B	100	115
C	35	40
L	420	480
<b>Weight</b>	11 kg	15 kg

C = apertura gancio / hook opening

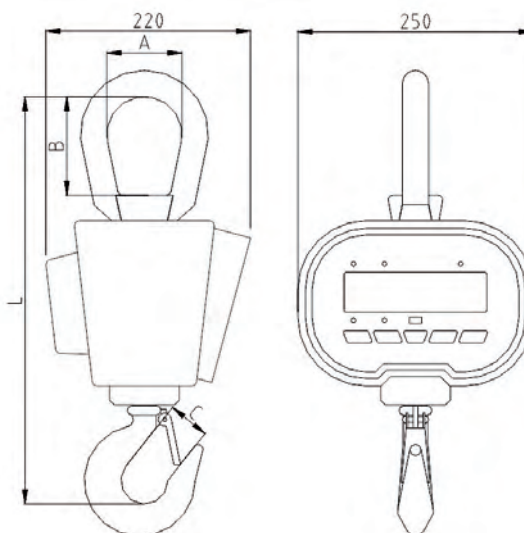

Dimensions (mm)

- Dinamometro digitale ultracompatto completo di grillo e gancio girevole.
- Display a Led rossi alta luminosità 5 digit da 30 mm.
- Telecomando fino a 10 metri di distanza.
- Custodia in alluminio pressofuso.
- Alimentazione con batteria interna ricaricabile 6V 3.2Ah. Alimentatore 230Vca/9Vcc per ricarica batteria (autonomia ca. 80 ore funzionamento continuato); inclusa batteria di scorta.
- Funzione HOLD (blocco del peso visualizzato).
- Totalizzazione delle singole pesate e totale pesate.
- Impostazione tara predeterminata (nota).
- Indicazione del peso netto/lordo.

- Crane scale with shackle and swivel hook.
- Five-digit red LED display (30 mm high).
- Remote-Control (max distance 10 m).
- Die-casting aluminium case.
- Power supply with internal rechargeable 6V 3.2Ah battery. Power adapter 230VAC / 9VDC to recharge battery (80 hours operating time of continuous functioning); included spare battery.
- HOLD function (block of the displayed weight).
- Individual weighing and weights totalization.
- Predetermined tare function.
- Net weight and gross indicator.

**CARATTERISTICHE TECNICHE**

**TECHNICAL FEATURES**

CLASSE DI PRECISIONE (% sul Fondo Scala)  
 GRADO DI PROTEZIONE  
 MAX LETTURE AL SECONDO  
 CARICO STATICO MASSIMO (% sul Fondo Scala)  
 CARICO DI ROTTURA (% sul Fondo Scala)  
 TEMPERATURA DI ESERCIZIO  
 UMIDITA' NON CONDENSANTE

+/- 0.03 % Full Scale  
 IP 64  
 10  
 150 % F.S.  
 400 % F.S.  
 -10°C / +40°C  
 10 - 90 %

ACCURACY CLASS (% of Full Scale)  
 PROTECTION RATING  
 MAX READINGS PER SECOND  
 SAFE OVERLOAD (% of Full Scale)  
 ULTIMATE OVERLOAD (% of Full Scale)  
 OPERATING TEMPERATURE RANGE  
 HUMIDITY (condensate free)

* <b>DTEZ3</b>	<b>3000 kg portata max. / nominal load</b> .....	<b>1 kg divisione / division</b> .....
* <b>DTEZ5</b>	<b>5000 kg portata max. / nominal load</b> .....	<b>2 kg divisione / division</b> .....
* <b>DTEZ10</b>	<b>10000 kg portata max. / nominal load</b> .....	<b>5 kg divisione / division</b> .....
<b>DTEZ20</b>	<b>20000 kg portata max. / nominal load</b> .....	<b>10 kg divisione / division</b> .....
<b>DTEZ30</b>	<b>30000 kg portata max. / nominal load</b> .....	<b>10 kg divisione / division</b> .....

**OPZIONI A RICHIESTA :**

- TARATURA con CERTIFICATO DI RIFERIBILITÀ SIT .....
- TELEDETEZ telecomando con display per visualizzazione via radio del peso (distanza 15 m) .....
- TELEDETEZPRINT telecomando con display e stampante .....
- Gancio per DTEZ3 .....
- Gancio per DTEZ5 .....
- Gancio per DTEZ10 .....

**OPTIONS ON REQUEST :**

- Calibration with SIT traceability certificate .....
- TELEDETEZ wireless remote control display for weight radio transmission (range 15 m) .....
- TELEDETEZPRINT wireless remote control display with printer .....
- Hook for DTEZ3 .....
- Hook for DTEZ5 .....
- Hook for DTEZ10 .....

**DTEZ3 - DTEZ5**

**DTEZ10 - DTEZ20 - DTEZ30**

**OPZIONE GANCIO (HOOK OPTION)**

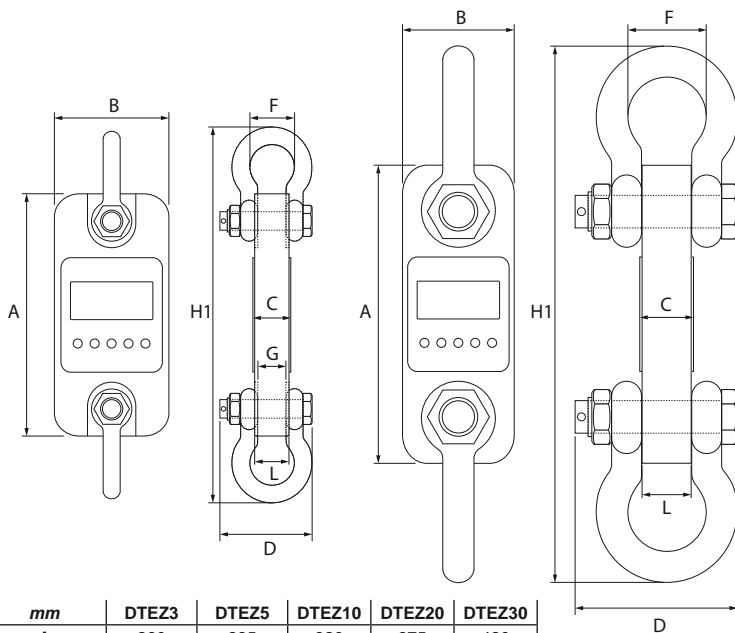

mm	DTEZ3	DTEZ5	DTEZ10	DTEZ20	DTEZ30
A	260	285	320	375	420
B	123	123	120	128	138
C	39	55	55	72	84
D	103	120	183	230	265
H1	365	405	535	660	740
H2	555	635	840	-	-
E	55	65	95	-	-
F	51	58	92	127	146
G	30	34	-	-	-
L	37	53	53	70	82
Weight	4.1 kg	6.2 kg	23.2 kg	44.6 kg	62.5 kg
Peso gancio Hook weight	3 kg	5.5 kg	5.9 kg	-	-
Material	Alluminio / Aluminium		Acciaio / Alloy steel		

**TELECOMANDI A RICHIESTA NECESSARI PER ESEGUIRE AUTONOMAMENTE LA TARATURA**  
**OPTIONAL REMOTE CONTROLS NEEDED TO PERFORM THE CALIBRATION AUTONOMOUSLY**



**VALIGETTA INCLUSA PER PORTATE DA 3 A 10 t (\*)**

**BRIEFCASE INCLUDED FOR NOMINAL LOAD 3 TO 10 t (\*)**

- Dinamometro digitale portatile completo di due grilli.
- Display LCD retroilluminato a 5 digit da 25 mm.
- A richiesta: telecomandi con stampante.
- Alimentazione con 3 batterie AA 1.5V (autonomia ca. 50 ore di funzionamento continuato).
- Funzione PICCO (massimo valore letto).
- Totalizzazione del peso.
- Indicazione del peso netto/lordo.
- (\*) Fornito con valigetta d'alluminio per portate da 3 a 10ton.

- Multifunction portable crane scale with two shackles.
- Five-digit backlit LCD display (25 mm).
- On request: remote control with printer.
- Power supply with three batteries AA 1.5V (50-hour operating time of continuous functioning).
- Peak function (maximum value read).
- Weight totalization.
- Net weight and gross indicator.
- (\*) Aluminum briefcase included for 3-10ton capacity.

**CARATTERISTICHE TECNICHE**

**TECHNICAL FEATURES**

CLASSE DI PRECISIONE (% sul Fondo Scala)  
 GRADO DI PROTEZIONE  
 MAX LETTURE AL SECONDO  
 CARICO STATICO MASSIMO (% sul Fondo Scala)  
 CARICO DI ROTTURA (% sul Fondo Scala)  
 TEMPERATURA DI ESERCIZIO  
 UMIDITA' NON CONDENSANTE

+/- 0.1 % Full Scale  
 IP 64  
 10  
 150 % F.S.  
 400 % F.S.  
 -10°C / +40°C  
 10 - 90 %

ACCURACY CLASS (% of Full Scale)  
 PROTECTION RATING  
 MAX READINGS PER SECOND  
 SAFE OVERLOAD (% of Full Scale)  
 ULTIMATE OVERLOAD (% of Full Scale)  
 OPERATING TEMPERATURE RANGE  
 HUMIDITY (condensate free)

**DTE30**      **30000 kg portata max. / nominal load** .....      **5 kg divisione / division** .....

**OPZIONI A RICHIESTA :**
**OPTIONS ON REQUEST :**

- TARATURA con CERTIFICATO DI RIFERIBILITÀ SIT .....

- Calibration with SIT traceability certificate .....



Dimensions mm

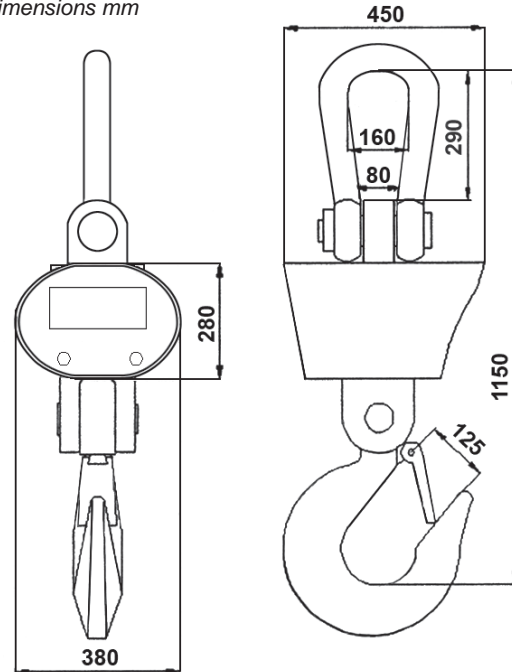

Weight = 165 kg

- Dinamometro digitale completo di grillo e gancio.
- Display a LED rossi alta luminosità, 5 digit da 58 mm.
- Telecomando fino a 15 m di distanza.
- Custodia in alluminio pressofuso.
- Alimentazione con batteria interna ricaricabile; alimentatore 230Vca / 9Vcc 1A per ricarica batteria. Batteria da 6 V / 10 Ah (autonomia di circa 80 ore di funzionamento continuato).
- Funzione HOLD (blocco del peso visualizzato).
- Totalizzazione delle singole pesate e totale pesate.
- Impostazione tara predeterminata.
- Indicazione del peso netto/lordo.

- Crane scale with shackle and hook.
- Five-digit red LED display (58 mm high).
- Remote-Control (distance max. 15 m)
- Die-casting aluminium case.
- Power supply with internal rechargeable; power adapter 230VAC / 9VDC to recharge battery. 6V / 10Ah battery (autonomy: 80-hour operating time of continuous functioning).
- HOLD function (block of the displayed weight).
- Individual weighing and weights totalization.
- Predetermined tare function.
- Net weight and gross indicator.

**CARATTERISTICHE TECNICHE**
**TECHNICAL FEATURES**



CLASSE DI PRECISIONE (% sul Fondo Scala)  
GRADO DI PROTEZIONE  
CARICO STATICO MASSIMO (% sul Fondo Scala)  
CARICO DI ROTTURA (% sul Fondo Scala)  
TEMPERATURA DI ESERCIZIO  
UMIDITA' NON CONDENSANTE

+/- 0.05 % Full Scale  
IP 64  
150 % F.S.  
500 % F.S.  
-10 / +50°C  
10 - 90 %

ACCURACY CLASS (% of Full Scale)  
PROTECTION RATING  
SAFE OVERLOAD (% of Full Scale)  
ULTIMATE OVERLOAD (% of Full Scale)  
OPERATING TEMPERATURE RANGE  
HUMIDITY (condensate free)

	Carico massimo statico Max static load	Dimensioni Dimensions
<b>ACN6 ACN15 ACN30 ACN50</b>	6 / 15 / 30 / 50 kg.....	300 x 300 mm .....
<b>ACN60 ACN120</b>	60 / 120 kg .....	400 x 400 mm .....
<b>ACN150 ACN300</b>	150 / 300 kg.....	600 x 600 mm .....
<b>ACN600</b>	600 kg.....	800 x 800 mm .....

OPZIONI A RICHIESTA :	OPTIONS ON REQUEST :
- Maggiorazione per portate fuori standard.....	- Additional price for non-standard platforms .....
- Versione ATEX  II 1 GD (zone 0-1-2-20-21-22).....	- ATEX version  II 1 GD (zone 0-1-2-20-21-22).....
- Colonna inox portaindicatore (Ø 38 mm, h 700 mm) con staffa in acciaio inox per fissaggio alla piattaforma .....	- Indicator stainless steel stand (Ø 38 mm, h 700 mm) with stainless steel bracket for platform mounting .....
- Colonna inox portaindicatore (Ø 38 mm, h 700 mm) con staffa in acciaio verniciato per fissaggio alla piattaforma .....	- Indicator stainless steel stand (Ø 38 mm, h 700 mm) with painted steel bracket for platform mounting .....

 **APPROVAZIONE OIML R60 C3**  
**C3** OIML R60 C3 APPROVED

 **ACN6 / 15 / 30 / 50 / 150 / 300: a richiesta versione approvata OIML R60 C4**  
**C4** ACN6 / 15 / 30 / 50 / 150 / 300: on request OIML R60 C4 version approved

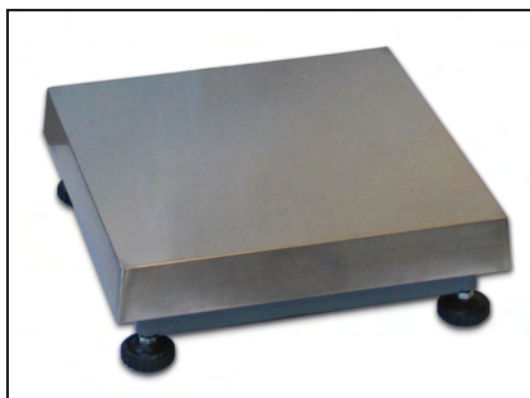

- STRUTTURA TUBOLARE IN ACCIAIO VERNICIATO
- PIANO DI CARICO IN ACCIAIO INOX AISI 304 APPOGGIATO
- CELLA DI CARICO IN LEGA D'ALLUMINIO IP65
- PIEDINI IN ACCIAIO ZINCATO E POLIAMMIDE
- ATTACCO PER COLONNA PORTAINDICATORE
- PAINTED STEEL TUBULAR STRUCTURE
- AISI 304 STAINLESS STEEL LOADING TOP (laid)
- SINGLE-POINT IP65 ALUMINUM LOAD CELL
- GALVANIZED STEEL & POLYAMID FEET
- CONNECTION FOR INDICATOR STAND

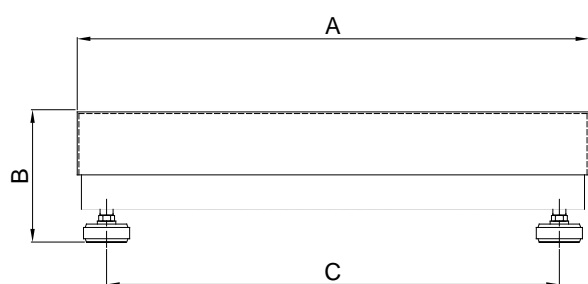

Dimensions (mm)

Code	Load cells capacities	Platforms	A	B	C	D	E	F	Gross Weight
ACN6 / 15 / 30 / 50	10 / 20 / 50 / 100 kg	300 x 300 mm	300	125	237	56	1	56	6.5 kg
ACN60 / 120	100 / 200 kg	400 x 400 mm	400	130	337	52	1	56	9.5 kg
ACN150 / 300	200 / 500 kg	600 x 600 mm	600	150	537	77	1.5	56	24.5 kg
ACN600	1000 kg	800 x 800 mm	800	170	715	90	1.8	56	50.5 kg

**COLONNA con STAFFA**  
STAND with BRACKET

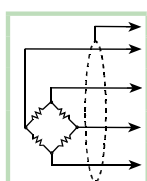



	ACN 6 - 120	ACN 150 - 300	ACN 600
SCHERMO (SHIELD)			
+ SEGNALE (+SIGNAL)	VERDE (GREEN)	VERDE (GREEN)	BLU (BLUE)
+ ALIMENT. (+EXCIT.)	ROSSO (RED)	ROSSO (RED)	ROSSO (RED)
* + REF./SENSE (+REF./SENSE)	BLU (BLUE)	BLU (BLUE)	MARRONE (BROWN)
- SEGNALE (-SIGNAL)	BIANCO (WHITE)	BIANCO (WHITE)	BIANCO (WHITE)
- ALIMENT. (-EXCIT.)	NERO (BLACK)	NERO (BLACK)	NERO (BLACK)
* - REF./SENSE (-REF./SENSE)	MARRONE (BROWN)	GIALLO (YELLOW)	GIALLO (YELLOW)

\* Dove previsto (where provided)

	Carico massimo statico Max static load	Dimensioni Dimensions
<b>AIN6</b> <b>AIN15</b> <b>AIN30</b> <b>AIN50</b>	6 / 15 / 30 / 50 kg .....	300 x 300 mm .....
* <b>AIN60</b> * <b>AIN120</b>	60 / 120 kg .....	400 x 400 mm .....
* <b>AIN150</b> * <b>AIN300</b>	150 / 300 kg .....	600 x 600 mm .....
<b>AIN600</b>	600 kg .....	800 x 800 mm .....

  

OPZIONI A RICHIESTA :	OPTIONS ON REQUEST :
- Maggiorazione per portate fuori standard .....	- Additional price for non-standard platforms .....
- Versione ATEX  II 1 GD (zone 0-1-2-20-21-22) .....	- ATEX version  II 1 GD (zone 0-1-2-20-21-22) .....
- Colonna inox portaindicatore (Ø 38 mm, h 700 mm) con staffa in acciaio inox per fissaggio alla piattaforma .....	- Indicator stainless steel stand (Ø 38 mm, h 700 mm) with stainless steel bracket for platform mounting .....
- Colonna inox portaindicatore (Ø 38 mm, h 700 mm) con staffa in acciaio verniciato per fissaggio alla piattaforma .....	- Indicator stainless steel stand (Ø 38 mm, h 700 mm) with painted steel bracket for platform mounting .....

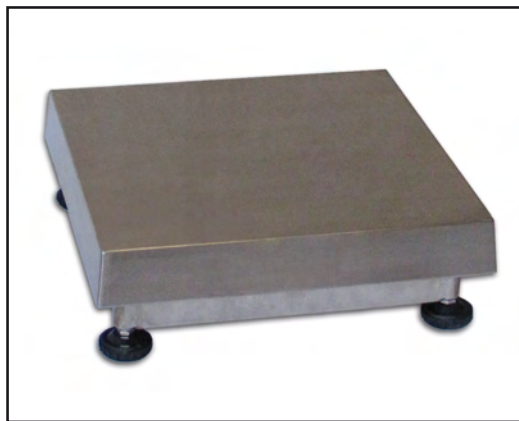

- STRUTTURA TUBOLARE IN ACCIAIO INOX AISI 304
- PIANO DI CARICO IN ACCIAIO INOX AISI 304 APOGGIATO
- CELLA DI CARICO IN LEGA D'ALLUMINIO IP65
- PIEDINI IN ACCIAIO INOX E POLIAMMIDE
- ATTACCO PER COLONNA PORTAINDICATORE
- AISI 304 STEEL TUBULAR STRUCTURE
- AISI 304 STEEL LOADING TOP (laid)
- SINGLE-POINT IP65 ALUMINIUM LOAD CELL
- STAINLESS STEEL & POLYAMID FEET
- CONNECTION FOR INDICATOR STAND

\* PER MOD.: AIN60/120/150/300  
 LA CELLA DI CARICO VIENE FORNITA CON KIT WATERPROOF INOX + GOMMA.  
 FOR MODELS: AIN60/120/150/300  
 THE LOAD CELL IS PROVIDED WITH STAINLESS STEEL WATERPROOF KIT + RUBBER.

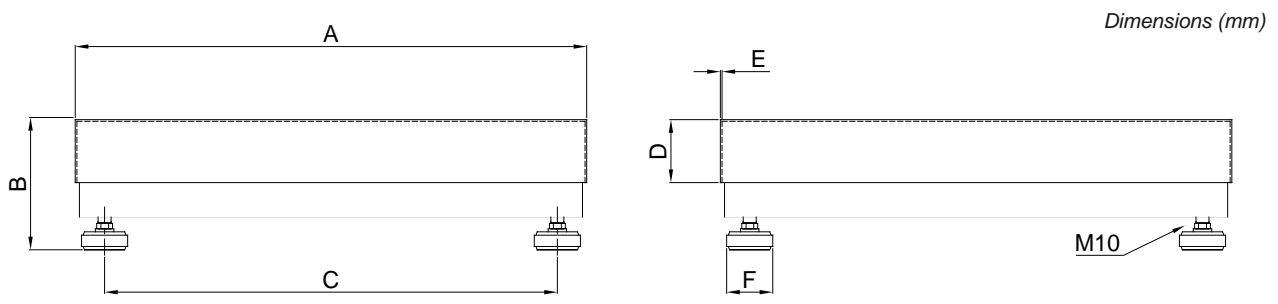

Code	Load cells capacities	Platforms	A	B	C	D	E	F	Gross Weight
AIN6 / 15 / 30 / 50	10 / 20 / 50 / 100 kg	300 x 300 mm	300	125	237	56	1	56	6.5 kg
AIN60 / 120	100 / 200 kg	400 x 400 mm	400	130	337	52	1	56	9.5 kg
AIN150 / 300	200 / 500 kg	600 x 600 mm	600	150	537	77	1.5	56	24.5 kg
AIN600	1000 kg	800 x 800 mm	800	170	715	90	1.8	56	50.5 kg

**COLONNA con STAFFA**  
 STAND with BRACKET

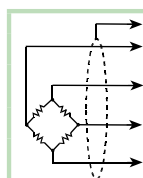

	AIN 6 - 120	AIN 150 - 300	AIN 600
SCHERMO (SHIELD)			
+ SEGNALE (+SIGNAL)	VERDE (GREEN)	VERDE (GREEN)	BLU (BLUE)
+ ALIMENT. (+EXCIT.)	ROSSO (RED)	ROSSO (RED)	ROSSO (RED)
** + SENSE (+REF./SENSE)	BLU (BLUE)	BLU (BLUE)	MARRONE (BROWN)
- SEGNALE (-SIGNAL)	BIANCO (WHITE)	BIANCO (WHITE)	BIANCO (WHITE)
- ALIMENT. (+EXCIT.)	NERO (BLACK)	NERO (BLACK)	GIALLO (YELLOW)
** - SENSE (+REF./SENSE)	MARRONE (BROWN)	GIALLO (YELLOW)	NERO (BLACK)

\*\* Dove previsto (where provided)



	Carico massimo statico Max static load	Dimensioni Dimensions
<b>AILN15 AILN30 AILN60 AILN150</b>	15 / 30 / 60 / 150 kg.....	400 x 400 mm .....
<b>AILN200 AILN300</b>	200 / 300 kg.....	600 x 600 mm .....

  

OPZIONI A RICHIESTA :	OPTIONS ON REQUEST :
- Maggiorazione per portate fuori standard.....	- Additional price for non-standard platforms .....
- Versione ATEX  II 1 GD (zone 0-1-2-20-21-22).....	- ATEX version  II 1 GD (zone 0-1-2-20-21-22).....
- Colonna inox portaindicatore (Ø 38 mm, h 700 mm) con staffa in acciaio inox per fissaggio alla piattaforma .....	- Indicator stainless steel stand (Ø 38 mm, h 700 mm) with stainless steel bracket for platform mounting .....
- IPX9K: Dichiarazione di conformità + Marcatura grado IPX9K per la cella di carico .....	- IPX9K: Declaration of conformity + IPX9K marking protection rating for load cell .....



- STRUTTURA TUBOLARI IN ACCIAIO INOX AISI 304
- PIANO DI CARICO IN ACCIAIO INOX AISI 304 APPOGGIATO
- CELLA DI CARICO IN ACCIAIO INOX IP68 SALDATO (a richiesta IPX9K)
- PIEDINI IN ACCIAIO INOX E POLIAMMIDE
- ATTACCO PER COLONNA PORTAINDICATORE

- AISI 304 STEEL TUBULAR STRUCTURE
- AISI 304 STEEL LOADING TOP (laid)
- IP68 WELDED STAINLESS STEEL LOAD CELL (on request IPX9K)
- STAINLESS STEEL & POLYAMID FEET
- CONNECTION FOR INDICATOR STAND

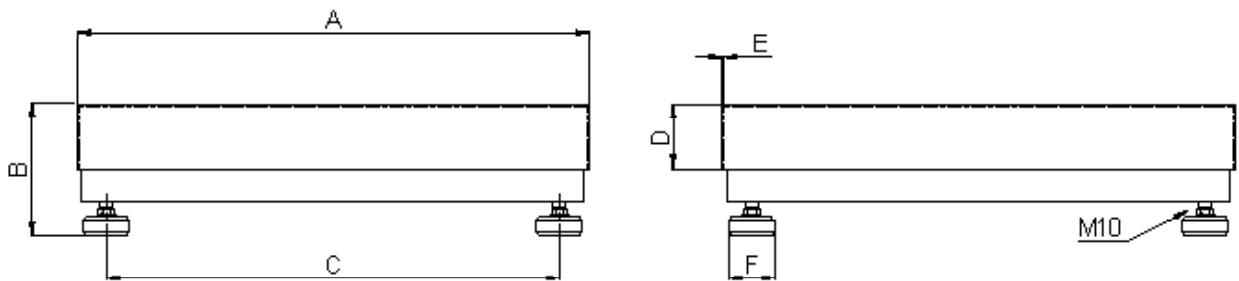

Code	Load cells capacities	Platforms	A	B	C	D	E	F	Gross Weight
AILN15 / 30	20 / 50 kg	400 x 400 mm	400	130	337	52	1	56	11.5 kg
AILN60 / 150	100 / 200 kg	400 x 400 mm	400	150	337	52	1	56	13.3 kg
AILN200 / 300	300 / 500 kg	600 x 600 mm	600	150	537	77	1.5	56	24.5 kg

### COLONNA con STAFFA STAND with BRACKET



SCHERMO	SHIELD
+ SEGNALE (BIANCO)	+ SIGNAL (WHITE)
+ ALIMENTAZIONE (VERDE) * + REF./SENSE (GIALLO)	+ EXCITATION (GREEN) + REF./SENSE (YELLOW)
- SEGNALE (ROSSO)	- SIGNAL (RED)
* - ALIMENTAZIONE (NERO) - REF./SENSE (BLU)	- EXCITATION (BLACK) - REF./SENSE (BLUE)

\* Dove previsto (where provided)

SCHERMO	SHIELD
+ SEGNALE (VERDE)	+ SIGNAL (GREEN)
+ ALIMENTAZIONE (ROSSO) * + REF./SENSE (BLU)	+ EXCITATION (RED) + REF./SENSE (BLUE)
- SEGNALE (BIANCO)	- SIGNAL (WHITE)
* - ALIMENTAZIONE (NERO) - REF./SENSE (GIALLO)	- EXCITATION (BLACK) - REF./SENSE (YELLOW)

\* Dove previsto (where provided)



Protezione contro l'acqua in caso di pulitura ad alta pressione/a getto di vapore (Test: acqua spruzzata da una distanza di max 150 mm). Pressione dell'acqua 100 bar; temperatura 80 °C; durata test 250 secondi (Normativa di riferimento DIN 40050-9).  
Water protection when cleaning high pressure / steam jet (Test: pressurized hot water is sprayed from a distance of 150 mm). Water pressure 100 bar; temperature 80 °C; test duration 250 seconds. (Reference standard DIN 40050-9).

# PIATTAFORME MONOCELLA CON PIANO DI CARICO INOX SINGLE CELL PLATFORMS WITH STAINLESS STEEL LOADING TOP

MN

	Carico massimo statico <i>Max static load</i>	Dimensioni <i>Dimensions</i>
MN75	75 kg .....	460 x 600 mm .....
MN150	150 kg .....	460 x 600 mm .....
MN300	300 kg .....	460 x 600 mm .....
<b>OPZIONI A RICHIESTA :</b>		<b>OPTIONS ON REQUEST :</b>
- Maggiorazione per portate fuori standard .....		- Additional price for non-standard platforms .....
- Versione ATEX  II 1 GD (zone 0-1-2-20-21-22) .....		- ATEX version  II 1 GD (zone 0-1-2-20-21-22) .....
- Colonna inox portaindicatore (Ø 38 mm, h 700 mm) con staffa in acciaio inox per fissaggio alla piattaforma .....		- Indicator stainless steel stand (Ø 38 mm, h 700 mm) with stainless steel bracket for platform mounting .....
- Colonna inox portaindicatore (Ø 38 mm, h 700 mm) con staffa in acciaio verniciato per fissaggio alla piattaforma .....		- Indicator stainless steel stand (Ø 38 mm, h 700 mm) with painted steel bracket for platform mounting .....

**APPROVAZIONE OIML R60 C3**  
**C3** OIML R60 C3 APPROVED

**A richiesta versione approvata OIML R60 C4**  
**C4** On request OIML R60 C4 version approved



- STRUTTURA TUBOLARE IN ACCIAIO VERNICIATO
- PIANO DI CARICO IN ACCIAIO INOX AISI 304 APPOGGIATO
- CELLA DI CARICO IN LEGA D'ALLUMINIO IP65
- PIEDINI IN ACCIAIO ZINCATO E POLIAMMIDE
- ATTACCO PER COLONNA PORTAINDICATORE
  
- PAINTED STEEL TUBULAR STRUCTURE
- AISI 304 STAINLESS STEEL LOADING TOP (laid)
- SINGLE-POINT IP65 ALUMINUM LOAD CELL
- GALVANIZED STEEL & POLYAMID FEET
- CONNECTION FOR INDICATOR STAND

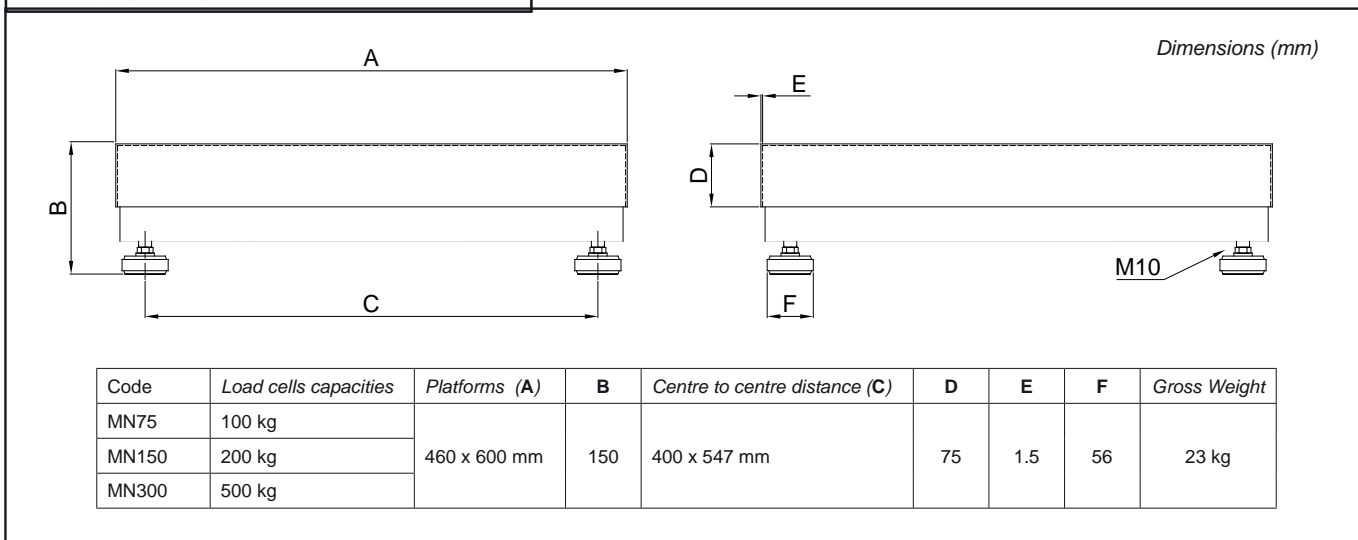

**COLONNA con STAFFA**  
*STAND with BRACKET*



	SCHERMO	SHIELD
→	+ SEGNALE (VERDE)	+ SIGNAL (GREEN)
→	+ ALIMENTAZIONE (ROSSO)	+ EXCITATION (RED)
→	* + REF./SENSE (BLU)	+ REF./SENSE (BLUE)
→	- SEGNALE (BIANCO)	- SIGNAL (WHITE)
→	* - ALIMENTAZIONE (NERO)	- EXCITATION (BLACK)
→	- REF./SENSE (GIALLO)	- REF./SENSE (YELLOW)

\* Dove previsto (where provided)

<b>P1250S5</b>	<b>max kg 1500</b> .....	dimens. 1250 x 1250 mm .....
<b>P1200P1500S5</b>	<b>max kg 1500</b> .....	dimens. 1200 x 1500 mm .....
<b>P1500S5</b>	<b>max kg 1500</b> .....	dimens. 1500 x 1500 mm .....
<b>TELP1250</b>	Telaio da infossare in acciaio zincato a freddo per P1250 con staffe di regolazione centraggio / Galvanized steel frame to be grounded for P1250 with center adjusting brackets.....	
<b>TELP1200P1500</b>	Telaio da infossare in acciaio zincato a freddo per P1200P1500 con staffe di regolazione centraggio / Galvanized steel frame to be grounded for P1200P1500 with center adjusting brackets.....	
<b>TELP1500</b>	Telaio da infossare in acciaio zincato a freddo per P1500 con staffe di regolazione centraggio / Galvanized steel frame to be grounded for P1250 with center adjusting brackets.....	
<b>P1250RAMP</b>	Rampa di accesso in acciaio verniciato (1250x1060xh110mm) / Painted steel access ramp	
<b>P1500RAMP</b>	Rampa di accesso in acciaio verniciato (1500x1060xh110mm) / Painted steel access ramp	

**OPZIONI A RICHIESTA :**

- Maggiorazione per portate fuori standard.....
- Versione **ATEX**  **II 1 GD (zone 0-1-2-20-21-22)**.....
- Colonna inox portaindicatore (Ø 38 mm, h 700 mm) con staffa in acciaio inox per fissaggio a pavimento.....
- Colonna inox portaindicatore (Ø 38 mm, h 700 mm) con staffa in acciaio verniciato per fissaggio a pavimento.....
- Quattro piastre PPV per fissaggio a pavimento (vedi pag. 92).....
- \* - **IPX9K**: Dichiarazione di conformità + Marcatura grado IPX9K per le quattro celle di carico.....

**OPTIONS ON REQUEST :**

- Additional price for non-standard platforms.....
- **ATEX version**  **II 1 GD (zone 0-1-2-20-21-22)**.....
- Indicator stainless steel stand (Ø 38 mm, h 700 mm) with stainless steel bracket for floor mounting.....
- Indicator stainless steel stand (Ø 38 mm, h 700 mm) with painted steel bracket for floor mounting.....
- Four plates mod. PPV for floor mounting (see page 92).....
- **IPX9K**: Declaration of conformity + IPX9K marking protection rating for 4 load cells.....



**APPROVAZIONE OIML R60 C3**  
**OIML R60 C3 APPROVED**



- **REALIZZATA IN ACCIAIO VERNICIATO**
- **PIANO DI CARICO ISPEZIONABILE LATO CELLE E CASSETTA GIUNZIONE INOX CON SCHEDA DI EGUALIZZAZIONE E CAVO DI USCITA A 6 FILI (5 m)**
- **4 CELLE DI CARICO A TAGLIO IP68 IN ACCIAIO INOX AISI 420 (a richiesta IPX9K\*)**
- **PIEDINI SNODATI IN ACCIAIO ZINCATO AUTOCENTRANTI SU SFERA**
- **2 FORI M12 PER GOLFARI DI SOLLEVAMENTO**

- **PAINTED STEEL CONSTRUCTION**
- **INSPECTABLE LOADING TOP ON CELLS AND JUNCTION BOX SIDES. STAINLESS STEEL JUNCTION BOX WITH EQUALIZATION BOARD AND 6 WIRES CABLE (5 m)**
- **4 SHEAR BEAM AISI 420 STAINLESS STEEL IP68 LOAD CELLS (on request IPX9K\*)**
- **GALVANIZED STEEL SELF-CENTERING ADJUSTABLE JOINTED FEET**
- **TWO M12 HOLES FOR LIFTING**

**Dimensions (mm)**

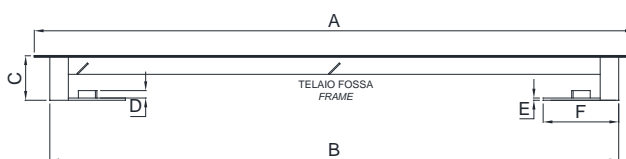
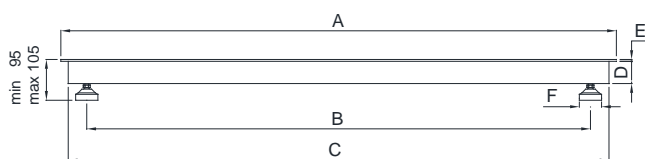

	Load Cells	A	B	C	D	E	F	Weight
<b>P1250S5</b>	500 kg	1250 x 1250	1115 (+/- 5)	1210	60	5	60	110 kg
<b>P1200P1500S5</b>	500 kg	1200 x 1500	1065 x 1370 (+/- 5)	1160 x 1460	60	5	60	112 kg
<b>P1500S5</b>	500 kg	1500 x 1500	1370 (+/- 5)	1460	60	5	60	148 kg

TELAIO FOSSA FRAME	A	B	C	D	E	F	Weight
<b>TELP1250</b>	1366 x 1366	1272 x 1272	110	15	8	200	30 kg
<b>TELP1200P1500</b>	1616 x 1316	1522 x 1222	110	15	8	200	33 kg
<b>TELP1500</b>	1616 x 1616	1522 x 1522	110	15	8	200	36 kg

**Su richiesta piattaforme CUSTOM con dimensioni e portate fuori standard: fino a 2500 x 2500 mm, fino a 6000 kg**  
**On request non-standard sizes and capacities CUSTOM platforms: up to 2500 x 2500 mm, up to 6000 kg**

**TELP1250 / TELP1500**



**P1250RAMP / P1500RAMP**



**COLONNA con STAFFA STAND with BRACKET**



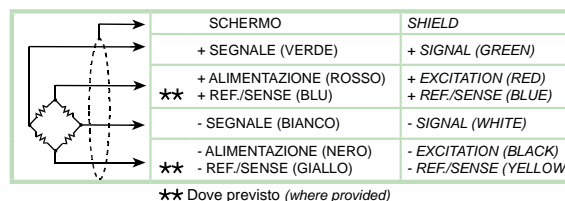

**VINCOLO ANTISPONAMENTO MODULE AGAINST LATERAL FORCES**



★★ Dove previsto (where provided)

\* **IPX9K** Protezione contro l'acqua in caso di pulitura ad alta pressione/a getto di vapore (Test: acqua spruzzata da una distanza di max 150 mm). Pressione dell'acqua 100 bar; temperatura 80 °C; durata test 250 secondi (Normativa di riferimento DIN 40050-9).  
 Water protection when cleaning high pressure / steam jet (Test: pressurized hot water is sprayed from a distance of 150 mm). Water pressure 100 bar; temperature 80 °C; test duration 250 seconds (Reference standard DIN 40050-9).

<b>P1250</b>	<b>max kg 3000</b>	.....	dimens. 1250 x 1250 mm	.....
<b>P1200P1500</b>	<b>max kg 3000</b>	.....	dimens. 1200 x 1500 mm	.....
<b>P1500</b>	<b>max kg 3000</b>	.....	dimens. 1500 x 1500 mm	.....
<b>TELP1250</b>	Telaio da infossare in acciaio zincato a freddo per P1250 con staffe di regolazione centraggio / Galvanized steel frame to be grounded for P1250 with center adjusting brackets.....			
<b>TELP1200P1500</b>	Telaio da infossare in acciaio zincato a freddo per P1200P1500 con staffe di regolazione centraggio / Galvanized steel frame to be grounded for P1200P1500 with center adjusting brackets.....			
<b>TELP1500</b>	Telaio da infossare in acciaio zincato a freddo per P1500 con staffe di regolazione centraggio / Galvanized steel frame to be grounded for P1500 with center adjusting brackets.....			
<b>P1250RAMP</b>	Rampa di accesso in acciaio verniciato (1250x1060xh110mm) / Painted steel access ramp			
<b>P1500RAMP</b>	Rampa di accesso in acciaio verniciato (1500x1060xh110mm) / Painted steel access ramp			
<b>OPZIONI A RICHIESTA :</b>		<b>OPTIONS ON REQUEST :</b>		
- Maggiorazione per portate fuori standard.....		- Additional price for non-standard platforms.....		
- Versione ATEX  II 1 GD (zone 0-1-2-20-21-22).....		- ATEX version  II 1 GD (zone 0-1-2-20-21-22).....		
- Colonna inox portaindicatore (Ø 38 mm, h 700 mm) con staffa in acciaio inox per fissaggio a pavimento.....		- Indicator stainless steel stand (Ø 38 mm, h 700 mm) with stainless steel bracket for floor mounting.....		
- Colonna inox portaindicatore (Ø 38 mm, h 700 mm) con staffa in acciaio verniciato per fissaggio a pavimento.....		- Indicator stainless steel stand (Ø 38 mm, h 700 mm) with painted steel bracket for floor mounting.....		
- Quattro piastre PPV per fissaggio a pavimento (vedi pag. 92).....		- Four plates mod. PPV for floor mounting (see page 92).....		
* - <b>IPX9K</b> : Dichiarazione di conformità + Marcatura grado IPX9K per le quattro celle di carico.....		- <b>IPX9K</b> : Declaration of conformity + IPX9K marking protection rating for 4 load cells.....		



**APPROVAZIONE OIML R60 C3**  
**C3 OIML R60 C3 APPROVED**



- REALIZZATA IN ACCIAIO VERNICIATO
- PIANO DI CARICO ISPEZIONABILE LATO CELLE E CASSETTA GIUNZIONE INOX CON SCHEDA DI EGUALIZZAZIONE E CAVO DI USCITA A 6 FILI (5 m)
- 4 CELLE DI CARICO A TAGLIO IP68 IN ACCIAIO INOX AISI 420 (a richiesta IPX9K\*)
- PIEDINI SNODATI IN ACCIAIO ZINCATO AUTOCENTRANTI SU SFERA
- 2 FORI M12 PER GOLFARI DI SOLLEVAMENTO

- PAINTED STEEL CONSTRUCTION
- INSPECTABLE LOADING TOP ON CELLS AND JUNCTION BOX SIDES. STAINLESS STEEL JUNCTION BOX WITH EQUALIZATION BOARD AND 6 WIRES CABLE (5 m)
- 4 SHEAR BEAM AISI 420 STAINLESS STEEL IP68 LOAD CELLS (on request IPX9K\*)
- GALVANIZED STEEL SELF-CENTERING ADJUSTABLE JOINTED FEET
- TWO M12 HOLES FOR LIFTING

Dimensions (mm)

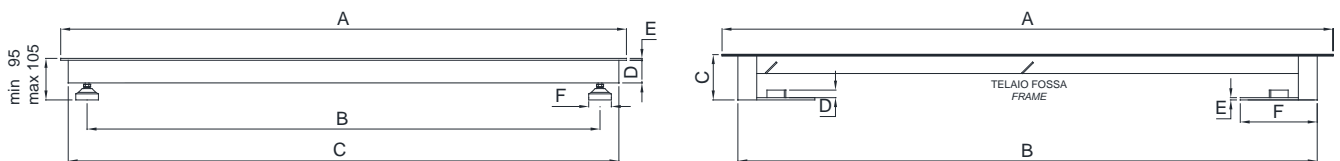

Load Cells	A	B	C	D	E	F	Weight	
<b>P1250</b>	1000 kg	1250 x 1250	1115 (+/- 5)	1210	60	5	60	110 kg
<b>P1200P1500</b>	1000 kg	1200 x 1500	1065 x 1370 (+/- 5)	1160 x 1460	60	5	60	112 kg
<b>P1500</b>	1000 kg	1500 x 1500	1370 (+/- 5)	1460	60	5	60	148 kg

TELAIO FOSSA FRAME	A	B	C	D	E	F	Weight
<b>TELP1250</b>	1366 x 1366	1272 x 1272	110	15	8	200	30 kg
<b>TELP1200P1500</b>	1616 x 1316	1522 x 1222	110	15	8	200	33 kg
<b>TELP1500</b>	1616 x 1616	1522 x 1522	110	15	8	200	36 kg

**Su richiesta piattaforme CUSTOM con dimensioni e portate fuori standard: fino a 2500 x 2500 mm, fino a 6000 kg**  
**On request non-standard sizes and capacities CUSTOM platforms: up to 2500 x 2500 mm, up to 6000 kg**



**COLONNA con STAFFA**  
**STAND with BRACKET**



**VINCOLO ANTISPONAMENTO**  
**MODULE AGAINST LATERAL FORCES**



\* **IPX9K** Protezione contro l'acqua in caso di pulitura ad alta pressione/a getto di vapore (Test: acqua spruzzata da una distanza di max 150 mm). Pressione dell'acqua 100 bar; temperatura 80 °C; durata test 250 secondi (Normativa di riferimento DIN 40050-9).  
 Water protection when cleaning high pressure / steam jet (Test: pressurized hot water is sprayed from a distance of 150 mm). Water pressure 100 bar; temperature 80 °C; test duration 250 seconds (Reference standard DIN 40050-9).

**P1250INOXNS5 max kg 1500** ..... dimens. 1250 x 1250 mm .....  
**P1500INOXNS5 max kg 1500** ..... dimens. 1500 x 1500 mm .....

**TELP1250INOX** Telaio da infossare inox AISI304 per P1250INOXN con staffe di regolazione centraggio /  
*AISI 304 stainless steel frame to be grounded for P1250INOXN with center adjusting brackets*

**TELP1500INOX** Telaio da infossare inox AISI304 per per P1500INOXN con staffe di regolazione centraggio /  
*AISI 304 stainless steel frame to be grounded for P1500INOXN with center adjusting brackets.*

**P1250INOXRAMP** Rampa di accesso in acciaio inox (1250x1060xh110mm) / *Stainless steel access ramp* ....

**OPZIONI A RICHIESTA :**

- Maggiorazione per portate fuori standard. ....
- Versione **ATEX**  **II 1 GD (zone 0-1-2-20-21-22)** .....
- Colonna inox portaindicatore (Ø 38 mm, h 700 mm) con staffa in acciaio inox per fissaggio a pavimento. ....
- Colonna inox portaindicatore (Ø 38 mm, h 700 mm) con staffa in acciaio verniciato per fissaggio a pavimento. ....
- Quattro piastre PPV per fissaggio a pavimento (vedi pag. 92) .....
- ★ - **IPX9K**: Dichiarazione di conformità + Marcatura grado IPX9K per le quattro celle di carico .....

**OPTIONS ON REQUEST :**

- Additional price for non-standard platforms .....
- **ATEX version**  **II 1 GD (zone 0-1-2-20-21-22)** .....
- Indicator stainless steel stand (Ø 38 mm, h 700 mm) with stainless steel bracket for floor mounting .....
- Indicator stainless steel stand (Ø 38 mm, h 700 mm) with painted steel bracket for floor mounting .....
- Four plates mod. PPV for floor mounting (see page 92) .....
- **IPX9K**: Declaration of conformity + IPX9K marking protection rating for 4 load cells. ....



**APPROVAZIONE OIML R60 C3**  
**C3** OIML R60 C3 APPROVED

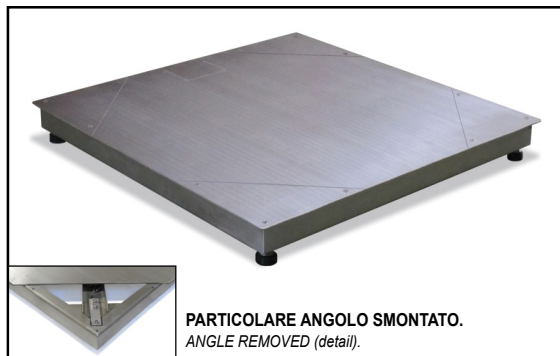

**PARTICOLARE ANGOLO SMONTATO.**  
**ANGLE REMOVED (detail).**

- **REALIZZATA IN ACCIAIO INOX AISI 304**
- **PIANO DI CARICO ISPEZIONABILE LATO CELLE E CASSETTA GIUNZIONE INOX CON SCHEDA DI EQUALIZZAZIONE E CAVO DI USCITA A 6 FILI (5 m)**
- **4 CELLE DI CARICO A TAGLIO IP68 IN ACCIAIO INOX 17-4PH (a richiesta IPX9K\*)**
- **PIEDINI SNODATI IN ACCIAIO INOX AISI 304 AUTOCENTRANTI SU SFERA**
- **2 FORI M12 PER GOLFARI DI SOLLEVAMENTO**
- **AISI 304 STAINLESS STEEL CONSTRUCTION**
- **INSPECTABLE LOADING TOP ON CELLS AND JUNCTION BOX SIDES. STAINLESS STEEL JUNCTION BOX WITH EQUALIZATION BOARD AND 6 WIRES CABLE (5 m)**
- **4 SHEAR BEAM 17-4PH STAINLESS STEEL IP68 LOAD CELLS (on request IPX9K\*)**
- **GALVANIZED STEEL SELF-CENTERING ADJUSTABLE JOINTED FEET**
- **TWO M12 HOLES FOR LIFTING**

**Dimensions (mm)**

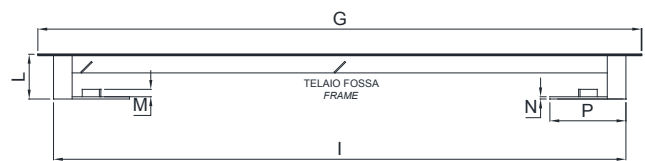
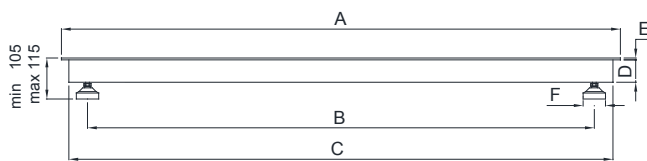

	Load Cells	A	B	C	D	E	F	Weight
<b>P1250INOXNS5</b>	500 kg	1250 x 1250	1110 (+/- 5)	1210	60	4.5	60	90 kg
<b>P1500INOXNS5</b>	500 kg	1500 x 1500	1370 (+/- 5)	1460	65±70	4.5	60	130 kg

TELAIO FOSSA FRAME	G	I	L	M	N	P	Weight
<b>TELP1250 INOX</b>	1366 x 1366	1272 x 1272	110	15	8	200	30 kg
<b>TELP1500 INOX</b>	1616 x 1616	1522 x 1522	110	15	8	200	36 kg

**Su richiesta piattaforme CUSTOM con dimensioni e portate fuori standard: fino a 2500 x 2500 mm, fino a 6000 kg**  
**On request non-standard sizes and capacities CUSTOM platforms: up to 2500 x 2500 mm, up to 6000 kg**

**TELP1250INOX / TELP1500INOX**



**P1250INOXRAMP**

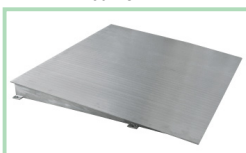

**COLONNA con STAFFA STAND with BRACKET**



**VINCOLO ANTISPOSTAMENTO MODULE AGAINST LATERAL FORCES**

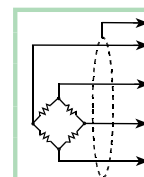
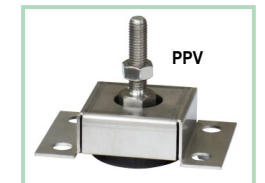

SCHERMO	SHIELD
+ SEGNALE (VERDE)	+ SIGNAL (GREEN)
+ ALIMENTAZIONE (ROSSO)	+ EXCITATION (RED)
★ + REF./SENSE (BLU)	+ REF./SENSE (BLUE)
- SEGNALE (BIANCO)	- SIGNAL (WHITE)
- ALIMENTAZIONE (NERO)	- EXCITATION (BLACK)
★ - REF./SENSE (GIALLO)	- REF./SENSE (YELLOW)

★ Dove previsto (where provided)



Protezione contro l'acqua in caso di pulitura ad alta pressione/a getto di vapore (Test: acqua spruzzata da una distanza di max 150 mm). Pressione dell'acqua 100 bar; temperatura 80 °C; durata test 250 secondi (Normativa di riferimento DIN 40050-9).  
 Water protection when cleaning high pressure / steam jet (Test: pressurized hot water is sprayed from a distance of 150 mm). Water pressure 100 bar; temperature 80 °C; test duration 250 seconds (Reference standard DIN 40050-9).

- P1250INOXN** max kg 3000 ..... dimens. 1250 x 1250 mm .....
- P1500INOXN** max kg 3000 ..... dimens. 1500 x 1500 mm .....
- TELP1250INOX** Telaio da infossare inox AISI304 per P1250INOXN con staffe di regolazione centraggio /  
AISI 304 stainless steel frame to be grounded for P1250INOXN with center adjusting brackets
- TELP1500INOX** Telaio da infossare inox AISI304 per P1500INOXN con staffe di regolazione centraggio /  
AISI 304 stainless steel frame to be grounded for P1500INOXN with center adjusting brackets
- P1250INOXRAMP** Rampa di accesso in acciaio inox (1250x1060xh110mm) / Stainless steel access ramp ....

### OPZIONI A RICHIESTA :

- Maggiorazione per portate fuori standard .....
- Versione **ATEX**  **II 1 GD (zone 0-1-2-20-21-22)** .....
- Colonna inox portaindicatore (Ø 38 mm, h 700 mm) con staffa in acciaio inox per fissaggio a pavimento .....
- Colonna inox portaindicatore (Ø 38 mm, h 700 mm) con staffa in acciaio verniciato per fissaggio a pavimento .....
- Quattro piastre PPV per fissaggio a pavimento (vedi pag. 92) .....
- ★ - **IPX9K**: Dichiarazione di conformità + Marcatura grado IPX9K per le quattro celle di carico .....

### OPTIONS ON REQUEST :

- Additional price for non-standard platforms .....
- **ATEX version**  **II 1 GD (zone 0-1-2-20-21-22)** .....
- Indicator stainless steel stand (Ø 38 mm, h 700 mm) with stainless steel bracket for floor mounting .....
- Indicator stainless steel stand (Ø 38 mm, h 700 mm) with painted steel bracket for floor mounting .....
- Four plates mod. PPV for floor mounting (see page 92) .....
- **IPX9K**: Declaration of conformity + IPX9K marking protection rating for 4 load cells .....



**APPROVAZIONE OIML R60 C3**  
OIML R60 C3 APPROVED

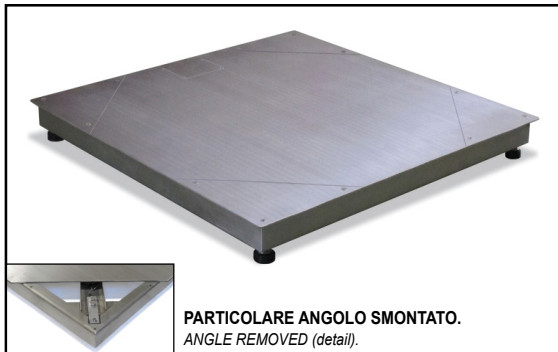

**PARTICOLARE ANGOLO SMONTATO.**  
ANGLE REMOVED (detail).

- **REALIZZATA IN ACCIAIO INOX AISI 304**
- **PIANO DI CARICO ISPEZIONABILE LATO CELLE E CASSETTA GIUNZIONE INOX CON SCHEDA DI EQUALIZZAZIONE E CAVO DI USCITA A 6 FILI (5 m)**
- **4 CELLE DI CARICO A TAGLIO IP68 IN ACCIAIO INOX 17-4PH (a richiesta IPX9K\*)**
- **PIEDINI SNODATI IN ACCIAIO INOX AISI 304 AUTOCENTRANTI SU SFERA**
- **2 FORI M12 PER GOLFARI DI SOLLEVAMENTO**
- **AISI 304 STAINLESS STEEL CONSTRUCTION**
- **INSPECTABLE LOADING TOP ON CELLS AND JUNCTION BOX SIDES. STAINLESS STEEL JUNCTION BOX WITH EQUALIZATION BOARD AND 6 WIRES CABLE (5 m)**
- **4 SHEAR BEAM 17-4PH STAINLESS STEEL IP68 LOAD CELLS (on request IPX9K\*)**
- **GALVANIZED STEEL SELF-CENTERING ADJUSTABLE JOINTED FEET**
- **TWO M12 HOLES FOR LIFTING**

### Dimensions (mm)

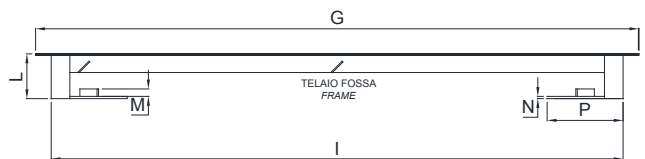
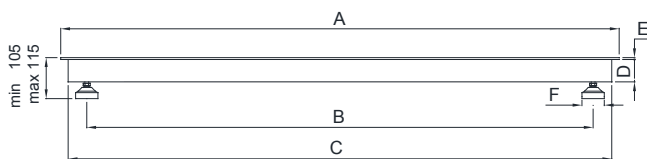

	Load Cells	A	B	C	D	E	F	Weight
<b>P1250 INOXN</b>	1000 kg	1250 x 1250	1110 (+/- 5)	1210	60	4.5	60	90 kg
<b>P1500 INOXN</b>	1000 kg	1500 x 1500	1370 (+/- 5)	1460	70	4.5	60	130 kg

TELAIO FOSSA FRAME	G	I	L	M	N	P	Weight
<b>TELP1250 INOX</b>	1366 x 1366	1272 x 1272	110	15	8	200	30 kg
<b>TELP1500 INOX</b>	1616 x 1616	1522 x 1522	110	15	8	200	36 kg

**Su richiesta piattaforme CUSTOM con dimensioni e portate fuori standard: fino a 2500 x 2500 mm, fino a 6000 kg**  
**On request non-standard sizes and capacities CUSTOM platforms: up to 2500 x 2500 mm, up to 6000 kg**

### TELP1250INOX / TELP1500INOX



**P1250INOXRAMP**

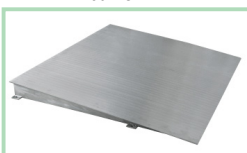

### COLONNA con STAFFA STAND with BRACKET



### VINCOLO ANTISPOSTAMENTO MODULE AGAINST LATERAL FORCES

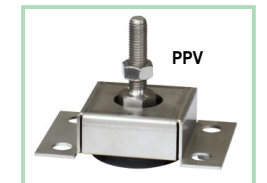

Protezione contro l'acqua in caso di pulitura ad alta pressione/a getto di vapore (Test: acqua spruzzata da una distanza di max 150 mm). Pressione dell'acqua 100 bar; temperatura 80 °C; durata test 250 secondi (Normativa di riferimento DIN 40050-9).  
Water protection when cleaning high pressure / steam jet (Test: pressurized hot water is sprayed from a distance of 150 mm). Water pressure 100 bar; temperature 80 °C; test duration 250 seconds (Reference standard DIN 40050-9).

SCHERMO	SHIELD
+ SEGNALE (VERDE)	+ SIGNAL (GREEN)
★ + ALIMENTAZIONE (ROSSO)	+ EXCITATION (RED)
★ + REF./SENSE (BLU)	+ REF./SENSE (BLUE)
- SEGNALE (BIANCO)	- SIGNAL (WHITE)
- ALIMENTAZIONE (NERO)	- EXCITATION (BLACK)
★ - REF./SENSE (GIALLO)	- REF./SENSE (YELLOW)

★ Dove previsto (where provided)

**PM max kg 1000**

**OPZIONI A RICHIESTA :**

- Maggiorazione per portate fuori standard.....
- Versione ATEX  II 1 GD (zone 0-1-2-20-21-22).....
- Colonna inox portaindicatore su piedistallo mobile in acciaio verniciato (colonna Ø 38 mm, h 700 mm) .....
- \* - **IPX9K**: Dichiarazione di conformità + Marcatura grado IPX9K per le quattro celle di carico.....

**OPTIONS ON REQUEST :**

- Additional price for non-standard platforms .....
- ATEX version  II 1 GD (zone 0-1-2-20-21-22).....
- Indicator stainless steel stand (Ø 38 mm, h 700 mm) on painted steel mobile pedestal .....
- **IPX9K**: Declaration of conformity + IPX9K marking protection rating for 4 load cells.....



Dimensions (mm)

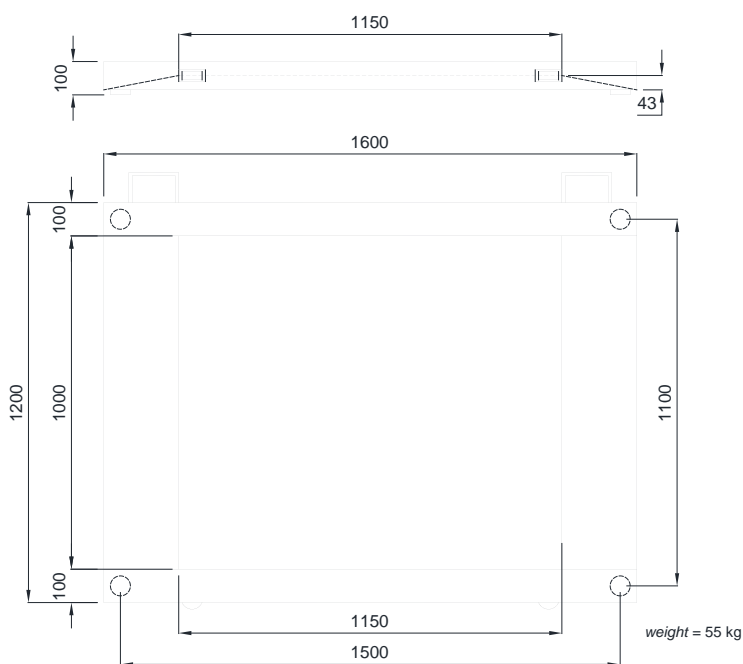

- ADATTE PER PESARE TRANSPALLETS, CARRELLI, etc.
- REALIZZATA IN ALLUMINIO ANODIZZATO
- STRUTTURA ULTRALEGGERA (PESO 55 kg)
- CASSETTA DI GIUNZIONE INOX CON SCHEDA DI EGUALIZZAZIONE E CAVO DI USCITA A 6 FILI (5m)
- 4 CELLE DI CARICO A TAGLIO IP68 DA 500kg IN ACCIAIO INOX AISI 420 (a richiesta IPX9\*)
- PIEDINI SNODATI IN ACCIAIO ZINCATO AUTOCENTRANTI SU SFERA
- RAMPE DI SALITA/DISCESA E SPONDE LATERALI
- MANIGLIE E RUOTE PER TRASPORTO INCLINATO



- SUITABLE FOR WEIGHING TROLLEYS, PALLETS, etc.
- ANODIZED ALUMINIUM CONSTRUCTION
- ULTRA-LIGHT STRUCTURE (weight 55 kg)
- STAINLESS STEEL JUNCTION BOX WITH EQUALIZATION BOARD AND 6 WIRES CABLE (5m)
- 4 SHEAR BEAM (500 kg) AISI 420 STAINLESS STEEL IP68 LOAD CELLS (on request IPX9\*)
- GALVANIZED STEEL SELF-CENTERING ADJUSTABLE JOINTED FEET
- ON/OFF RAMPS AND SIDE RAILS
- HANDLES AND WHEELS FOR INCLINED TRANSPORT

\* **IPX9K** Protezione contro l'acqua in caso di pulitura ad alta pressione/a getto di vapore (Test: acqua spruzzata da una distanza di max 150 mm). Pressione dell'acqua 100 bar; temperatura 80 °C; durata test 250 secondi (Normativa di riferimento DIN 40050-9).  
 Water protection when cleaning high pressure / steam jet (Test: pressurized hot water is sprayed from a distance of 150 mm). Water pressure 100 bar; temperature 80 °C; test duration 250 seconds (Reference standard DIN 40050-9).

	SCHERMO	SHIELD
	+ SEGNALE (VERDE)	+ SIGNAL (GREEN)
	+ ALIMENTAZIONE (ROSSO) + REF./SENSE (BLU)	+ EXCITATION (RED) + REF./SENSE (BLUE)
	- SEGNALE (BIANCO)	- SIGNAL (WHITE)
	- ALIMENTAZIONE (NERO) - REF./SENSE (GIALLO)	- EXCITATION (BLACK) - REF./SENSE (YELLOW)

**COLONNA MOBILE**  
MOBILE PEDESTAL STAND



<b>PX</b>	<b>max kg 3000</b> .....	acciaio verniciato / <i>painted steel</i> .....
<b>PXI</b>	<b>max kg 3000</b> .....	acciaio inox AISI 304 / <i>AISI 304 stainless steel</i> .....
<b>OPZIONI A RICHIESTA :</b>		
-	Maggiorazione per portate fuori standard .....	- <i>Additional price for non-standard platforms</i> .....
-	Versione <b>ATEX</b>  <b>II 1 GD (zone 0-1-2-20-21-22)</b> .....	- <i>ATEX version</i>  <b>II 1 GD (zone 0-1-2-20-21-22)</b> .....
-	Colonna inox portaindicatore su piedistallo mobile in acciaio verniciato (colonna Ø 38 mm, h 700 mm) .....	- <i>Indicator stainless steel stand (Ø 38 mm, h 700 mm) on painted steel mobile pedestal</i> .....
* -	<b>IPX9K:</b> Dichiarazione di conformità + Marcatura grado IPX9K per le quattro celle di carico .....	- <i>IPX9K: Declaration of conformity + IPX9K marking protection rating for 4 load cells</i> .....



**APPROVAZIONE OIML R60 C3**

**C3** OIML R60 C3 APPROVED

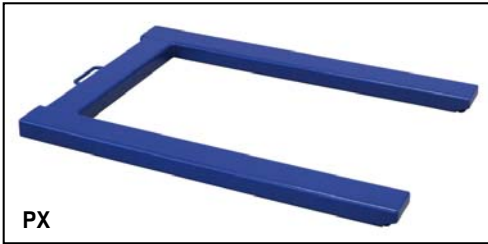

**PX**

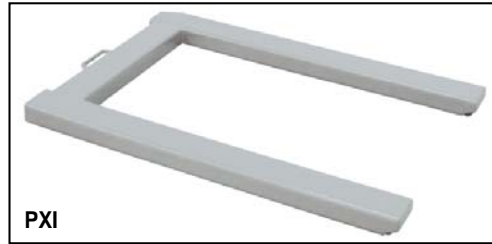

**PXI**

- Pesa pallet con quattro celle di carico a taglio:  
 PX: celle 1000 kg in acciaio inox AISI 420, IP68 (a richiesta IPX9K \*).  
 PXI: celle 1000 kg in acciaio inox 17-4 PH, IP68 (a richiesta IPX9K \*).
- Dimensioni 1250 x 840 x h 95 mm (altezza minima).
- Due ruote e maniglia per trasporto inclinato.
- Piedini snodati:  
 per PX in acciaio zincato;  
 per PXI in acciaio inox AISI 304.
- Cassetta di giunzione inox con scheda di equalizzazione e cavo di uscita a 6 conduttori, lunghezza 5 metri.

- *Pallet-weighing with four shear beam load cells:*  
 PX: *load cells 1000kg, AISI 420 stainless steel, IP68 (IPX9K\* on request);*  
 PXI: *load cells 1000kg, 17-4PH stainless steel, IP68 (IPX9K\* on request).*
- *Dimensions 1250 x 840 x h 95 mm (minimum).*
- *Two wheels and handles for moving.*
- *Jointed feet:*  
*galvanized steel feet for PX;*  
*AISI 304 stainless steel feet for PXI.*
- *Stainless steel junction box with equalization board, six-wire cable, 5 meters long.*

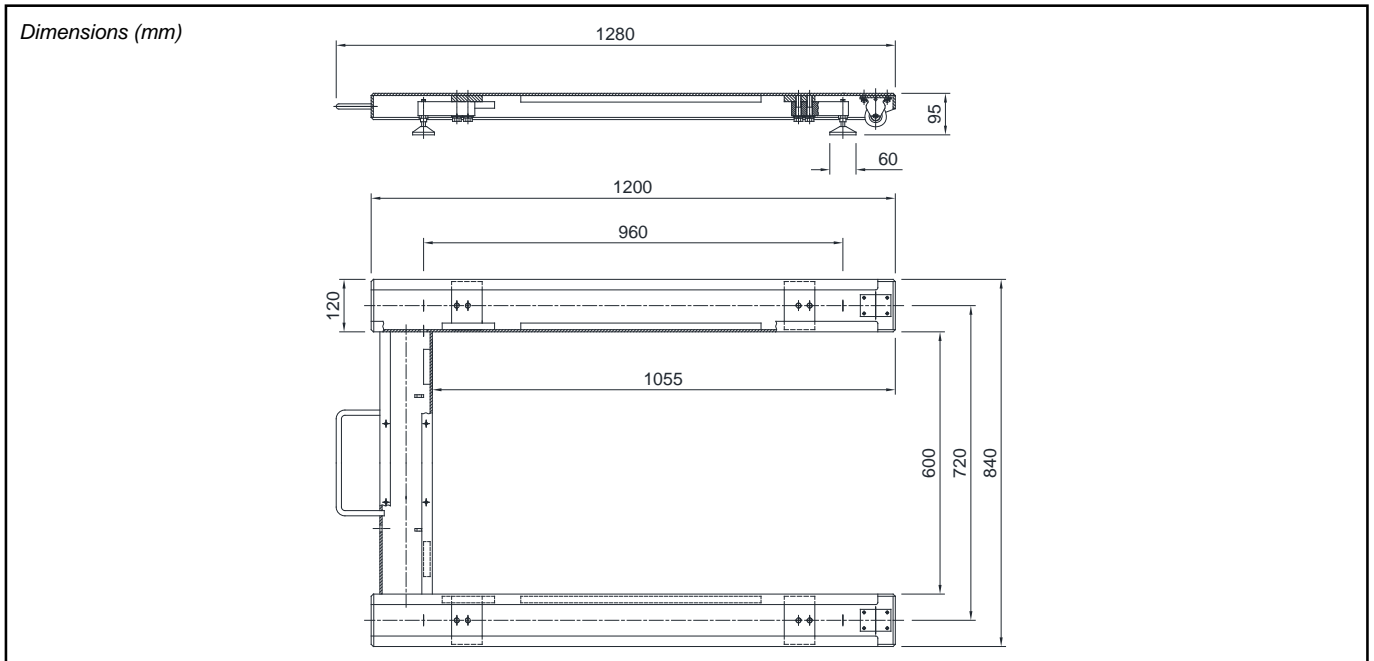

**COLONNA MOBILE**  
**MOBILE PEDESTAL STAND**



	SCHERMO	SHIELD
+	SEGNALE (VERDE)	+ SIGNAL (GREEN)
+	ALIMENTAZIONE (ROSSO)	+ EXCITATION (RED)
★★	REF./SENSE (BLU)	+ REF./SENSE (BLUE)
-	SEGNALE (BIANCO)	- SIGNAL (WHITE)
-	ALIMENTAZIONE (NERO)	- EXCITATION (BLACK)
★★	REF./SENSE (GIALLO)	- REF./SENSE (YELLOW)

★★ Dove previsto (where provided)



Protezione contro l'acqua in caso di pulitura ad alta pressione/a getto di vapore (Test: acqua spruzzata da una distanza di max 150 mm). Pressione dell'acqua 100 bar; temperatura 80 °C; durata test 250 secondi (Normativa di riferimento DIN 40050-9).  
 Water protection when cleaning high pressure / steam jet (Test: pressurized hot water is sprayed from a distance of 150 mm). Water pressure 100 bar; temperature 80 °C; test duration 250 seconds (Reference standard DIN 40050-9).



